

| PART | DESCRIPTION | MATERIAL |
|------|-------------|------------------|
| A | AC254-150-A | N-BK7 & N-SF5 |
| B | LENS MOUNT | 6061-T6 ALUMINUM |
| C | SM1RR | |

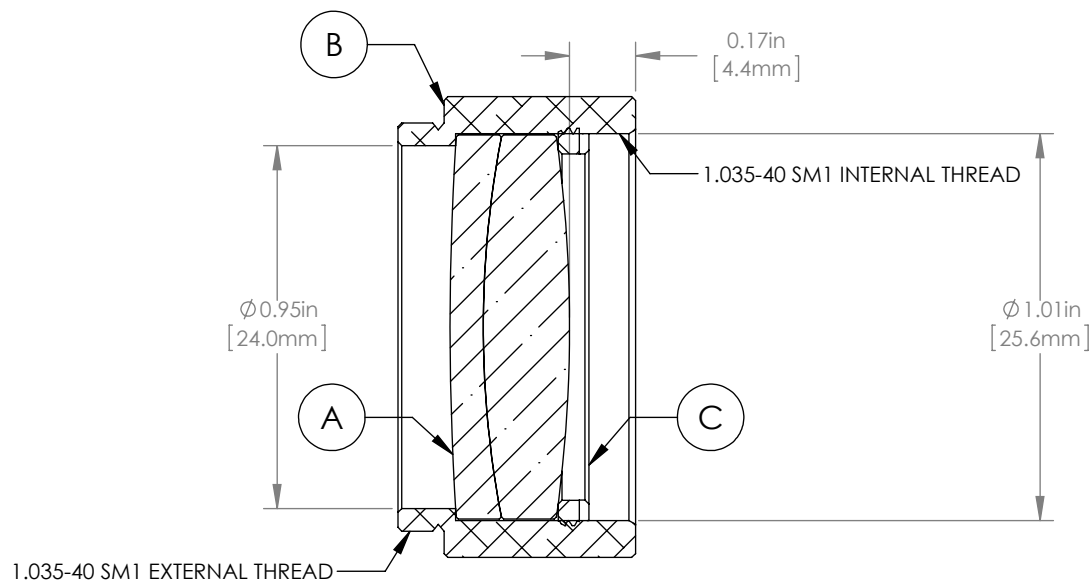
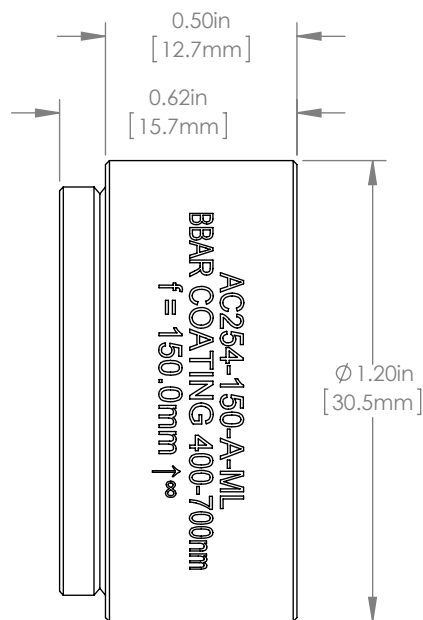

NOTES/SPECIFICATIONS:

1. LENS DIAMETER: 25.4mm +0.00/-0.10mm
2. LENS CENTER THICKNESS: 7.9mm
3. FOCAL LENGTH: 150.0mm ±1%
4. WORKING DISTANCE (REF): 142.7mm
5. CLEAR APERTURE: 90% OF LENS DIAMETER
6. LENS CENTRATION: <3arcmin
7. SURFACE QUALITY: 40-20 SCRATCH-DIG
8. COATING: BBAR $R_{avg} < 0.5\%$ FROM 400-700nm
0° AOI ON OUTER OPTICAL SURFACES

FOR INFORMATION ONLY
NOT FOR MANUFACTURING PURPOSES

| | | | | |
|---|------|-----------|-------------------------------------|---------------|
| DRAWING PROJECTION | | | THORLABS www.thorlabs.com | |
| | NAME | DATE | MOUNTED AC254-150-A | |
| DRAWN | EMT | 11/MAR/13 | MATERIAL | |
| APPROVAL | BW | 10/MAR/15 | SEE TABLE | REV C |
| COPYRIGHT © 2013 BY THORLABS | | | ITEM # | APPROX WEIGHT |
| VALUES IN PARENTHESIS ARE CALCULATED AND MAY CONTAIN ROUND OFF ERRORS | | | AC254-150-A-ML | 18.14 g |