

FIBER SPECIFICATIONS					
ITEM #	CORE DIAMETER	CLADDING DIAMETER	COATING DIAMETER	NA	WAVELENGTH RANGE
FT600UMT	600 ± 10µm	630 ± 10µm	1040 ± 30µm	0.39	300nm - 1200nm

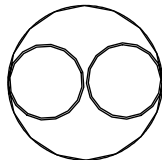
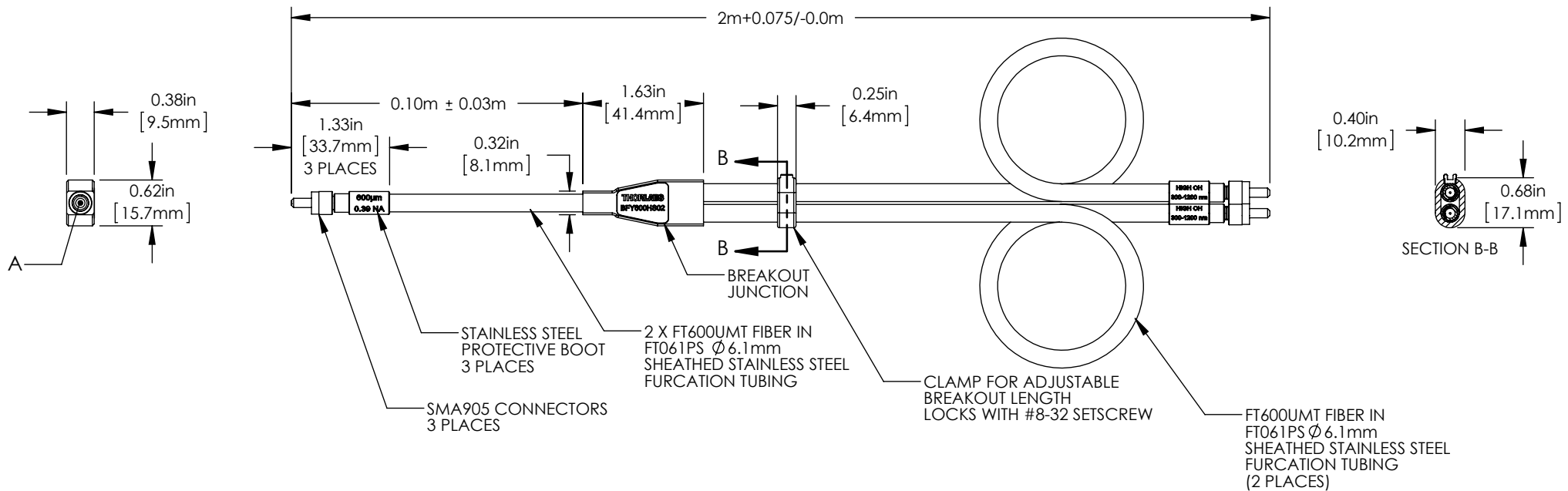

DETAIL A
SCALE 16 : 1
FRONT VIEW OF COMMON END

FOR INFORMATION ONLY
NOT FOR MANUFACTURING PURPOSES

DRAWING PROJECTION			THORLABS www.thorlabs.com	
NAME	DATE	BIFURCATED CABLE, TWO 600µm, 0.39 NA, HIGH OH FIBERS SMA, 2m		
DRAWN	IR	04/NOV/14	MATERIAL	
APPROVAL	BAG	06/AUG/15	N/A	
COPYRIGHT © 2015 BY THORLABS			ITEM #	APPROX WEIGHT
VALUES IN PARENTHESIS ARE CALCULATED AND MAY CONTAIN ROUND OFF ERRORS			BFY600HS02	0.14 kg
			REV	B