



DTS50(/M) 50 mm Translation Stage

User Guide



Original Instructions

Contents

Chapter 1 Safety	3
1.1 <i>Safety Information</i>	3
1.2 <i>General Warnings</i>	3
1.3 <i>Introduction</i>	4
1.3.1 <i>Multi-Axis Configurations</i>	5
Chapter 2 Installation	7
2.1 <i>Unpacking</i>	7
2.2 <i>Mounting</i>	7
2.2.1 <i>General</i>	7
2.2.2 <i>Locking Mechanism</i>	8
2.2.3 <i>Mounting Directly to the Work Surface</i>	8
2.2.4 <i>Fitting the Spacer Plate</i>	9
2.2.5 <i>Building an XY Configuration</i>	10
2.2.6 <i>Adding a Vertical (Z) Axis</i>	11
2.3 <i>Mounting Equipment to the Stage</i>	12
2.4 <i>Transportation</i>	12
2.5 <i>Operation</i>	12
2.6 <i>Dimensions</i>	13
2.6.1 <i>DTS50(M)</i>	13
Chapter 3 Specifications	14
3.1 <i>Specifications</i>	14
3.2 <i>Parts List</i>	14
Chapter 4 Thorlabs Worldwide Contacts	15

Chapter 1 Safety

1.1 Safety Information

For the continuing safety of the operators of this equipment, and the protection of the equipment itself, the operator should take note of the **Warnings, Cautions** and **Notes** throughout this handbook and, where visible, on the product itself.

The following safety symbols may be used throughout the handbook and on the equipment itself.



Caution



Given when there is a risk of injury to users.



Caution



Given when there is a risk of damage to the product.

Note

Clarification of an instruction or additional information.

1.2 General Warnings



Warnings



If this equipment is used in a manner not specified by the manufacturer, the protection provided by the equipment may be impaired. In particular, excessive moisture may impair operation.

Spillage of fluid, such as sample solutions, should be avoided. If spillage does occur, clean up immediately using absorbant tissue. Do not allow spilled fluid to enter the internal mechanism.

The equipment is for indoor use only.

Chapter 2 Overview

2.1 Introduction

The DTS50(M) dovetail translation stage is an entry-level positioner for use in general purpose positioning applications. It provides a travel range of 50 mm (2"), with 1 mm (0.04") travel per revolution of the adjuster. The design uses a precision-rolled M6 x 1.0 mm pitch leadscrew for smooth linear positioning along the entire range of travel. The moving platform is lockable via a side-located screw to guard against accidental movement.

The stage can be bolted directly to the optical table (see Section 3.2.3.), or it can be secured using four CL6 clamps (two on each side) as shown below. The DTSA1 and DTSA2 base plates can be used to create extra space (5 mm and 10 mm respectively) between the mounting surface and the stage - seeSection 3.2.4.

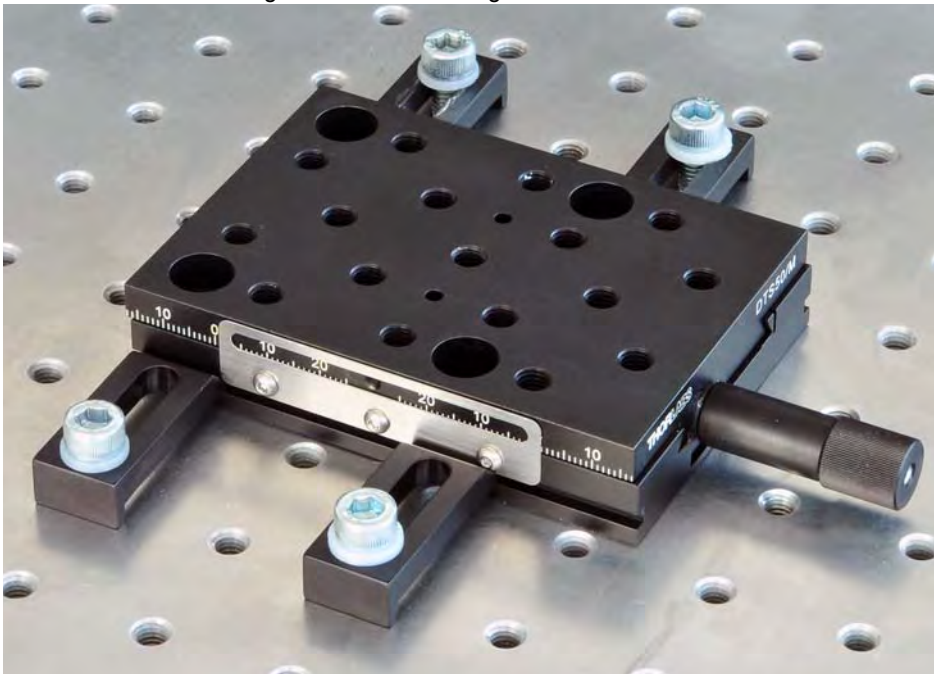

Fig. 2.1 DTS50 stage held with four CL6 clamps

2.1.1 Multi-Axis Configurations

The modular design allows two stages to be assembled into 2-axis and 3-axis configurations. Dowels are included with the purchase of each stage so that perpendicularity between the two translation directions is maintained. See Section 3.2.5. and Section 3.2.6. for more details.



Fig. 2.2 DTS50 series linear long travel stage – typical XY configuration

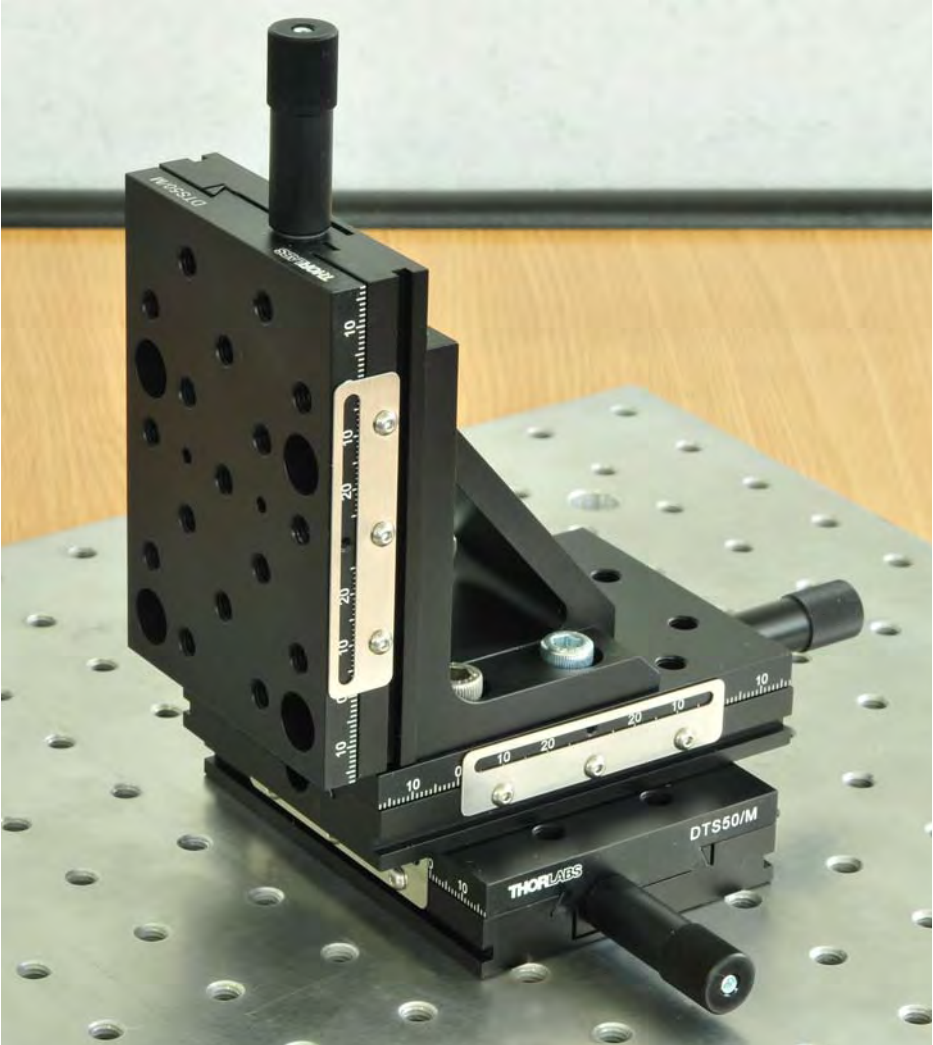

Fig. 2.3 DTS50 stage – typical XYZ configuration

Chapter 3 Installation

3.1 Unpacking

Notes

During handling or shipping, the moving platform must be constrained to avoid damage to the bearings.
Retain the packing in which the unit was shipped, for use in future transportation.



Caution



The stage is shipped with a plate fitted to the side, which locks the carriage during transit and in applications where accidental adjustment is undesirable. The locking screw on these plates must be loosened before the stage is used - see section Section 3.2.2.

3.2 Mounting

3.2.1 General

The DTS50 stage can be mounted directly to the work surface as shown in Section 3.2.3. For additional versatility, a base plate and angle bracket are available for use in horizontal or vertical mounting configurations - see Section 3.2.4. to Section 3.2.6. When mounting the stage close to other equipment, ensure that the travel of the moving platform is not obstructed.

The range of travel is 50 mm total, that is ± 25 mm about the nominal position.



Caution



When mounting components, or fitting the stage within an application, do not apply excessive pressure to the moving platform as this may damage the bearing mechanism.

Note

The DTS50 stages can quickly be assembled into XY, XZ, YZ and XYZ configurations - see Section 3.2.5. and Section 3.2.6. The stages, brackets and plates are supplied complete with dowels, which ensure an accurate, orthogonal assembly.

3.2.2 Locking Mechanism

The stage is shipped with a plate fitted to the side, which locks the carriage during transit, and in applications where accidental adjustment is undesirable. The locking screw on these plates should be loosened before the stage is used as shown below.

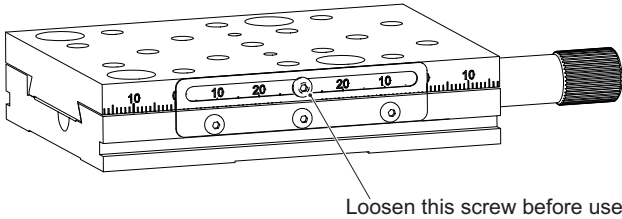

Fig. 3.1 Loosening the Locking Screw

3.2.3 Mounting Directly to the Work Surface

Referring to Fig. 3.2, proceed as follows:

- 1) Adjust the actuator to position the moving carriage such that the mounting holes in the base are clearly visible through the holes in the top plate.
- 2) Fit four bolts (M6 x 10 or 1/4-20 x 3/8", not supplied) through the holes in the top platform and tighten to secure the stage to the work surface.

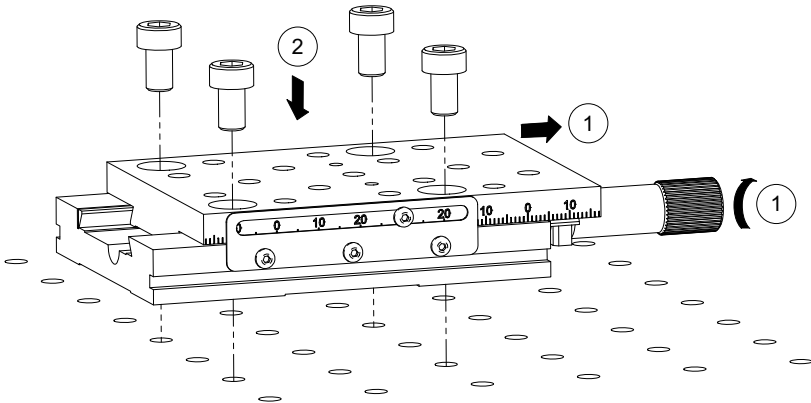

Fig. 3.2 Bolting the stage to the work surface

3.2.4 Fitting the Spacer Plate

A 5 mm (DTSA01) and a 10 mm (DTSA02) spacer plate are available to raise the height of the top surface to 25 mm or 30 mm respectively.

To fit a spacer plate, refer to Fig. 3.3 and proceed as follows:

- 1) Adjust the actuator to position the moving carriage such that the mounting holes in the base are clearly visible through the holes in the top plate.
- 2) Position the stage on the base plate, ensuring that the through holes in the spacer plate are clearly visible through the holes in the top plate.
- 3) Fit four bolts (M6 x 15 or 1/4-20 x 1/2", not supplied) through the holes in the top platform and tighten to secure the stage to the work surface.

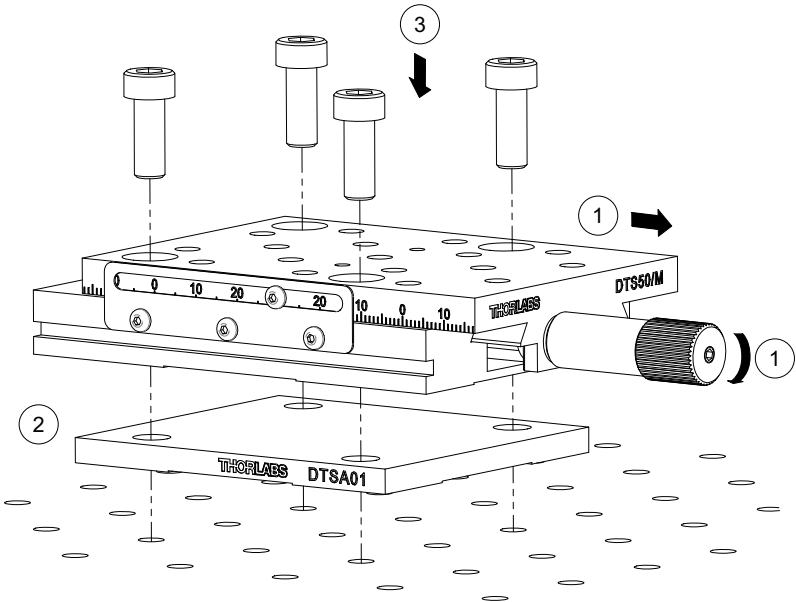

Fig. 3.3 Fitting the base plate

3.2.5 Building an XY Configuration

Bolt the X-axis stage to the work surface as detailed in Section 3.2.3. or Section 3.2.4. then, referring to Fig. 3.4, proceed as follows:

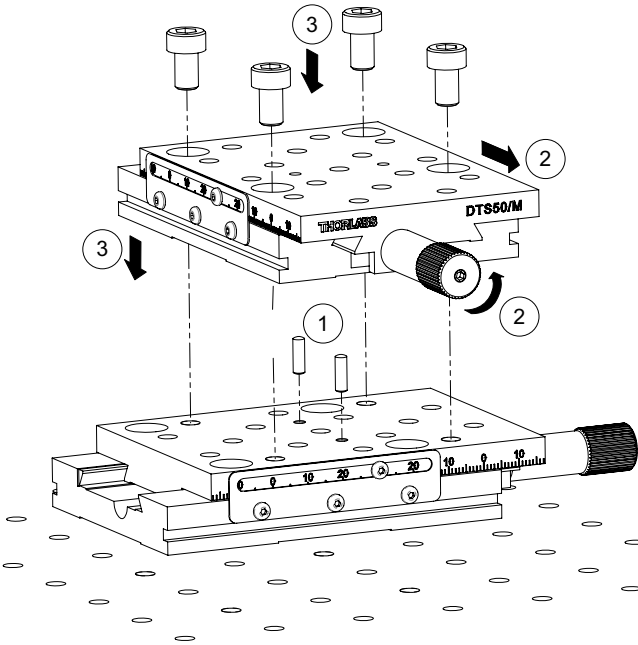

Fig. 3.4 Building an XY Configuration

- 1) Fit the dowels supplied to the top plate of the lower stage.
- 2) Adjust the actuator to position the moving carriage of the upper stage such that the mounting holes in the base are clearly visible through the holes in the top plate.
- 3) Locate the upper stage on the dowels fitted at item (1) then fit four bolts (M6 x 10 or 1/4-20 x 3/8", not supplied) through the holes in the upper stage and tighten to secure the stage to the moving platform of the stage beneath.



Caution



Use only bolts of the stated length. Longer bolts will protrude into the stage and damage the internal mechanism.

3.2.6 Adding a Vertical (Z) Axis

Assemble an X or XY configuration as detailed in Section 3.2.3. to Section 3.2.5. then, referring to Fig. 3.5 proceed as follows:

- 1) Fit the dowels supplied, into the moving platform on the lower stage assembly.
- 2) Fit the angle bracket (DTSA03) onto the moving platform of the stage, ensuring that the dowels fitted at item (1) locate correctly in the holes on the underside of the angle bracket.

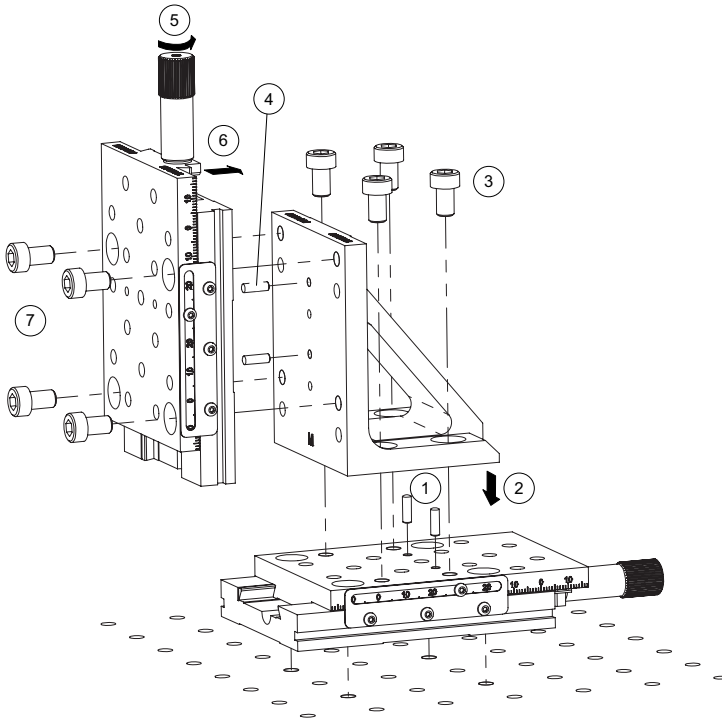

Fig. 3.5 Adding a Vertical Axis

- 3) Fit four bolts (M6 x 10 or 1/4-20 x 3/8" not supplied), through the holes in the base of the angle bracket, and tighten to secure the bracket to the lower assembly.



Caution



Use only bolts of the stated length. Longer bolts will protude into the stage and damage the internal mechanism.

- 4) Fit the dowels supplied to the vertical mounting face of the angle bracket.

- 5) Adjust the actuator to position the moving carriage of the vertical stage such that the mounting holes in the base are clearly visible through the holes in the top plate.
- 6) Fit the vertical-axis stage into place ensuring that the dowels fitted at item (4) locate correctly into the holes in the back surface of the angle bracket.
- 7) Fit four bolts (M6 x 10 or 1/4-20 x 3/8", not supplied) through the holes in the upper stage and tighten to secure the stage to the angle bracket



Caution



Use only bolts of the stated length. Longer bolts will protrude into the stage and damage the internal mechanism.

3.3 Mounting Equipment to the Stage



Caution



The weight attached to the moving platform must not exceed 40 kg (88 lb) if the stage is mounted horizontally, or 10 kg (22 lb) if mounted vertically.

Do not apply excessive forces to the moving platform.

The top platform of the stage features an array of M6 (1/4"-20) mounting holes for fitting accessories such as fiber clamps, mirror mounts etc. - see Fig. 3.6.

3.4 Transportation



Caution



When packing the unit for shipping, use the original packing. If this is not available, use a strong box and surround the unit with at least 100 mm of shock absorbent material.

Before the stage is packed for transit, adjust the actuators to the center of travel and then tighten the locking mechanism - see Section 3.2.2.

3.5 Operation

Turn the adjuster clockwise/anticlockwise to move the top platform forward/backwards. The lead screw has a 1 mm pitch which means that the top platform will move 1 mm (0.04") per revolution of the adjuster.

A graduated scale is etched onto each side of the moving platform. The metric stage has 1 millimeter graduations, the imperial stage has 1/40" graduations.

3.6 Dimensions

3.6.1 DTS50(/M)

All Dimensions in mm (inches)

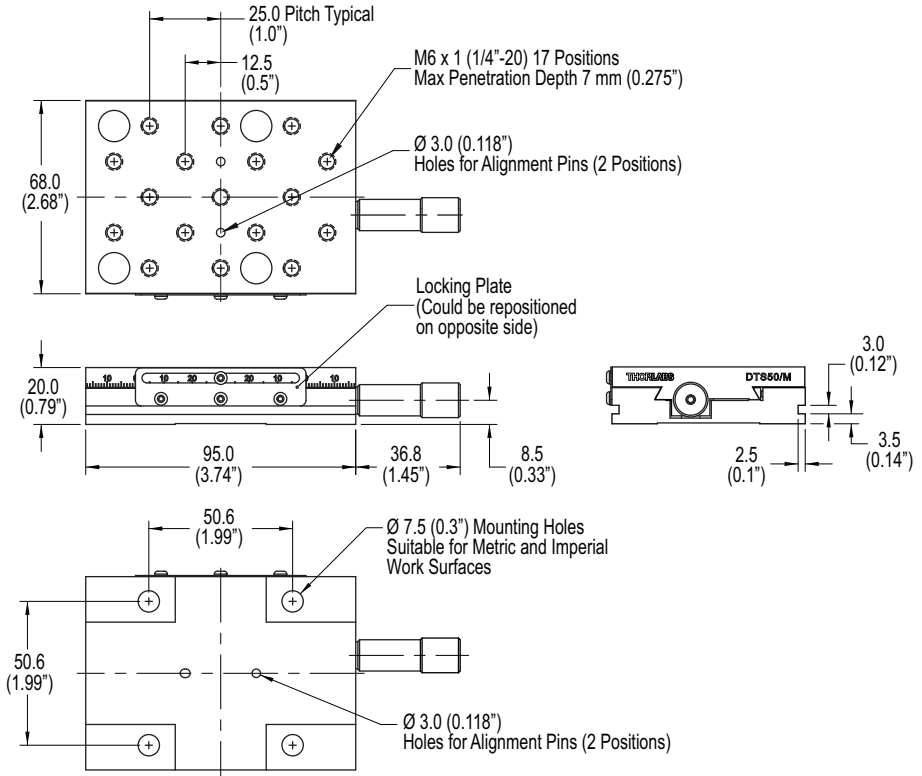

Fig. 3.6 Dimensions – DTS50(/M)

Chapter 4 Specifications

4.1 Specifications

Parameter	Value
Travel Range	50 mm
Horizontal Load Capacity	40 kg (88 lb)
Vertical Load Capacity	10 kg (22 lb)
Top Surface Parallelism	1200 μ Rad
Angular Deviation	\pm 300 μ Rad
Staightness	Horizontal \pm 15.00 μ m Vertical \pm 7.00 μ m
Stiffness	Pitch 150.00 μ Rad/Nm Yaw 460.00 μ Rad/Nm
Weight	0.31 kg (0.68 lbs)

Note

Backlash is not specified because the stage design does not contain a backlash spring.

4.2 Parts List

Description	Part Number
5 mm Spacer Plate	DTSA01
10 mm Spacer Plate	DTSA02
Right Angle Bracket	DTSA03

Chapter 5 Thorlabs Worldwide Contacts

For technical support or sales inquiries, please visit us at www.thorlabs.com/contact for our most up-to-date contact information.



USA, Canada, and South America

Thorlabs, Inc.
sales@thorlabs.com
techsupport@thorlabs.com

Europe

Thorlabs GmbH
europe@thorlabs.com

France

Thorlabs SAS
sales.fr@thorlabs.com

Japan

Thorlabs Japan, Inc.
sales@thorlabs.jp

UK and Ireland

Thorlabs Ltd.
sales.uk@thorlabs.com
techsupport.uk@thorlabs.com

Scandinavia

Thorlabs Sweden AB
scandinavia@thorlabs.com

Brazil

Thorlabs Vendas de Fotônicos Ltda.
brasil@thorlabs.com

China

Thorlabs China
chinasales@thorlabs.com



THORLABS
www.thorlabs.com