

ROTATION: $\pm 5^\circ$
 ACCURACY: 10 ARCMIN.

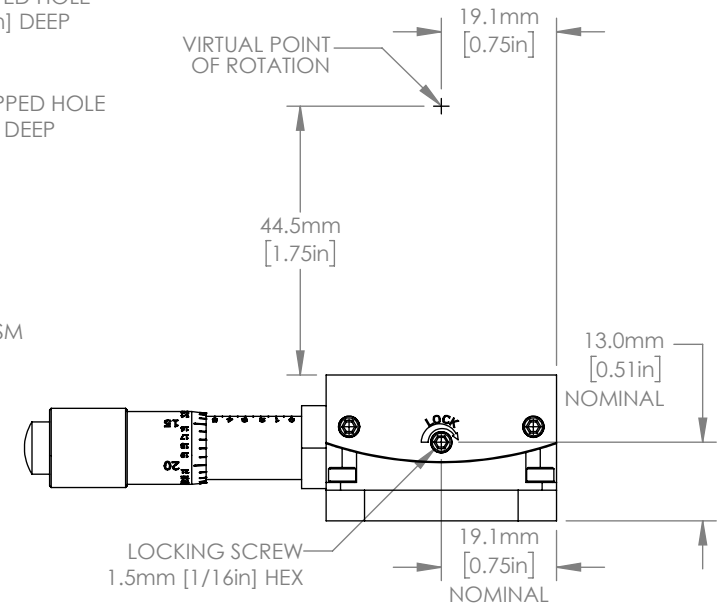
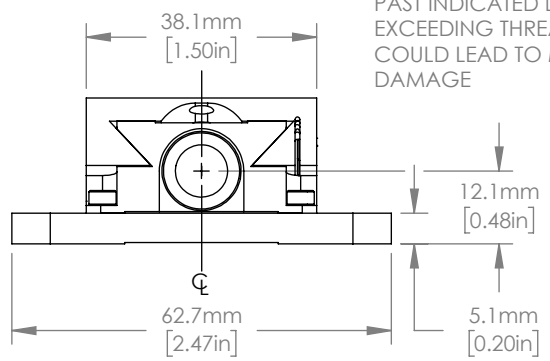
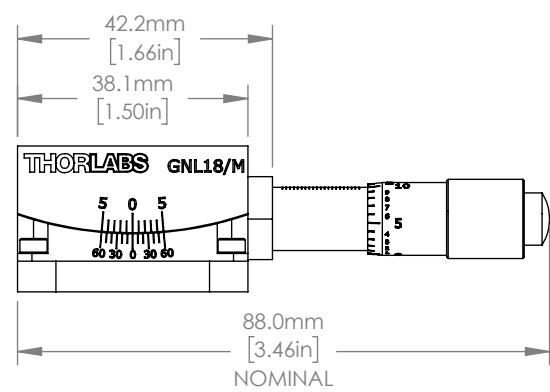

FOR INFORMATION ONLY
 NOT FOR MANUFACTURING PURPOSES

DRAWING PROJECTION					THORLABS www.thorlabs.com	
NAME	DATE	METRIC GONIOMETER, 1.75"				
DRAWN	BL	16/SEP/10	MATERIAL		REV E	
APPROVAL	TC	16/SEP/10	N/A			
COPYRIGHT © 2013 BY THORLABS			ITEM #	APPROX WEIGHT		
VALUES IN PARENTHESIS ARE CALCULATED AND MAY CONTAIN ROUND OFF ERRORS			GNL18/M	0.13 kg		