



HLS635 Handheld Laser Source

User Guide



















Table of Contents

Chapter 1	Warning Symbol Definitions	1
Chapter 2	Safety	2
Chapter 3	Description	3
Chapter 4	Setup	4
4.1.	<i>Initial Battery Charge</i>	4
4.2.	<i>Quick Start Information</i>	4
Chapter 5	Operation	5
5.1.	<i>Turning on the Source</i>	6
5.2.	<i>Adjusting the Laser Output Power</i>	6
5.3.	<i>Turning the Laser Off</i>	6
5.4.	<i>Charging the Unit</i>	7
5.4.1.	Battery Discharging	7
Chapter 6	Specifications	8
6.1.	<i>Handheld Source</i>	8
6.2.	<i>Power Supply</i>	8
Chapter 7	Mechanical Drawing	9
Chapter 8	Troubleshooting and Cleaning	10
Chapter 9	Regulatory	11
9.1.	<i>Waste Treatment is Your Own Responsibility</i>	11
9.2.	<i>Ecological Background</i>	11
Chapter 10	Certificate of Conformance	12
Chapter 11	Thorlabs Worldwide Contacts	13

Chapter 1 Warning Symbol Definitions



Below is a list of warning symbols you may encounter in this manual or on your device.

Symbol	Description
	Direct Current
	Alternating Current
	Both Direct and Alternating Current
	Earth Ground Terminal
	Protective Conductor Terminal
	Frame or chassis Terminal
	Equipotentiality
	On (Supply)
	Off (Supply)
	In Position of a Bi-Stable Push Control
	Out Position of a Bi-Stable Push Control
	Caution, Risk of Electric Shock
	Caution, Hot Surface
	Caution, Risk of Danger
	Warning, Laser Radiation
	Caution, Spinning Blades May Cause Harm

Chapter 2 Safety

All statements regarding safety of operation and technical data in this instruction manual will only apply when the unit is operated correctly.

 **WARNING** 
This unit must not be operated in explosive environment.

 **WARNING** 
Avoid Exposure – Radiation Emitted from apertures.
Do not look into the laser aperture while the laser is on. Injury to the eye may result.



 **Important Note** 
The HLS635 has been designed to provide many hours of trouble-free performance. To ensure proper operation, be sure follow the instructions below.

The unit is supplied with a battery charger which has a multi-blade wall adapter. Choose the plug adapter which matches the socket style for your location. The correct plug adapter must be attached to the battery charger before the battery can be charged or wall power operation can begin. Make sure that the line voltage rating marked on the battery charger agrees with your local supply voltage. Do not use any other battery charger to charge this product. Use of other types of battery chargers could result in damage to the product and personal injury.

There are no user serviceable parts in this product.

This device can only be returned when packed into the complete original packaging, including all foam packing inserts. If necessary, ask for a replacement package.

Mobile telephones, cellular phones or other radio transmitters should not to be used within the range of three meters of this unit since the electromagnetic field intensity may exceed the maximum allowed disturbance values according to EN50082-1.

Chapter 3 Description

This compact, handheld fiber-coupled laser source (measuring only 5.33" x 2.74" x 0.94") is intended to be used as a portable alignment laser though it is well suited for any task requiring a fiber coupled red laser. The laser output of the HLS635 may be set in 3 modes: low power (~1 mW), high power (≥ 2.5 mW), and a pulse mode that switches the laser from high power to off at 2 Hz. The selected mode is indicated by indicator lights on the front panel of the HLS635. The output is FC/PC coupled using the standard LPS-635 pigtail without the aluminum cover. The unit includes an internal 3.6 V NiMH rechargeable battery and charger. A red rubber cover boot with a kickstand is also included. This boot may be removed if desired.

The DC power supply is a universal type and will work with line voltages between 100 and 240 VAC from 50 to 60 Hz @ +/- 10%. Connect the appropriate adapter for the wall plug style after removing the temporary spacer. Connect the 2.1 mm plug to the front of the HLS635 if charging is needed.



Chapter 4 Setup



ATTENTION!



The battery does not arrive fully charged, but may have some residual charge. It should not be used until it is fully charged. Follow the instructions below for initial charging instructions.

4.1. Initial Battery Charge

Before using the HLS laser source cordlessly, the battery must be fully charged. The unit may be plugged in and used with the included power supply, but the battery will not charge while the unit is in operation.

1. Make sure the adapter for your local mains power is properly installed and seated onto the power supply.
2. Plug the power supply into the mains outlet.
3. Plug the power supply into the handheld laser.
4. A green LED will light next to the word Charging on the front of the unit.
5. When the device is fully charged, the LED will turn off.

4.2. Quick Start Information

The HLS635 can be used right out of the box safely, but it must be connected to the AC mains during use. In addition, the battery will not charge while the device is powered on and enabled. See the operating instructions on the follow page for more information.

1. Make sure the adapter for your local mains power is properly installed and seated onto the power supply.
2. Plug the power supply into the mains outlet.
3. Plug the power supply into the handheld laser.

Chapter 5 Operation

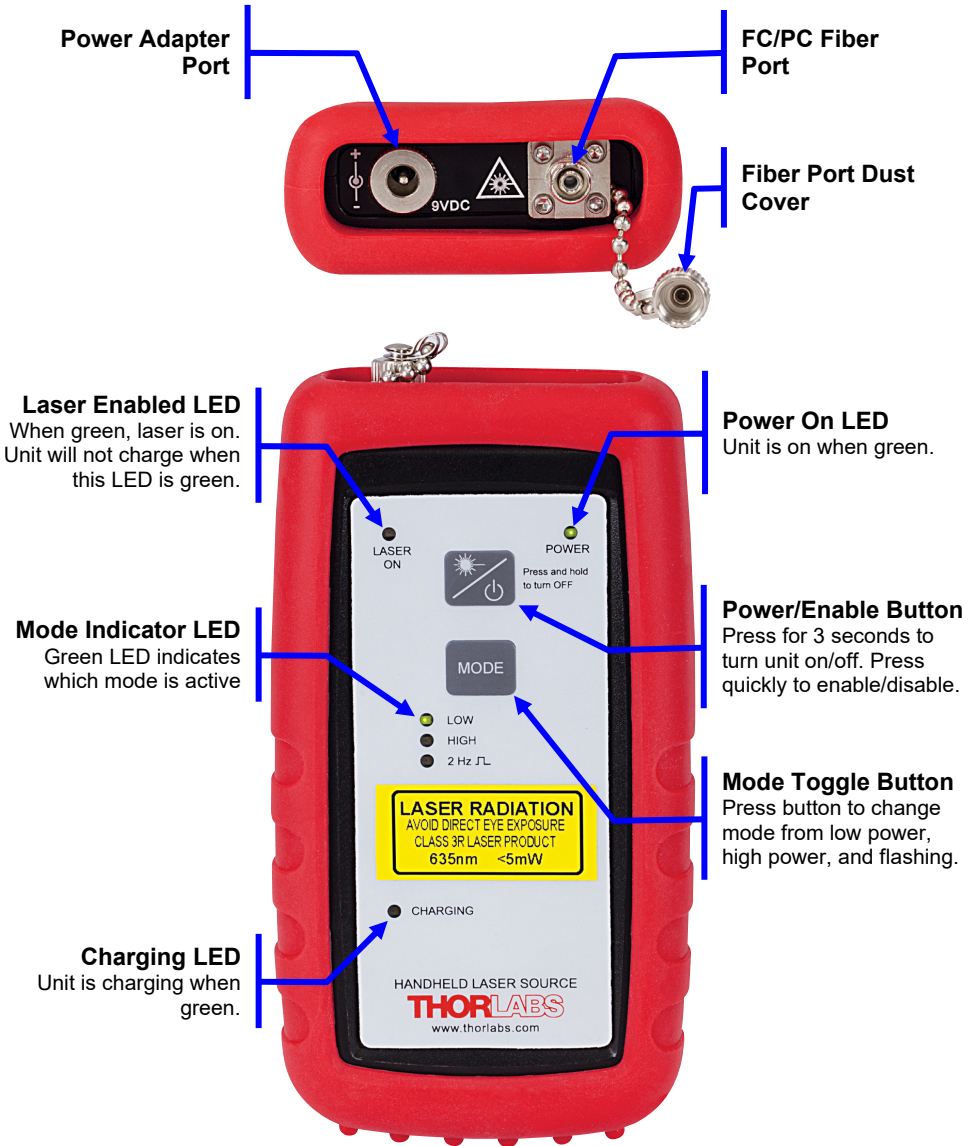

5.1. Turning on the Source

The HLS635 can be used right out of the box safely, but it must be connected to an AC outlet during use. Also, the battery will not charge while the device is powered on and enabled.

The operation of the HLS is the same for power and cordless operation.

1. Remove the dust cap from the connector, clean the connector on an FC/PC fiber patch cable, and insert it into the connector on the HSL.
2. Depress the Power/Enable button until the Power LED and one of the Mode Indicator LEDs light, about 3 seconds.
3. Select the desired mode by briefly depressing the Mode button. The three modes will cycle from Low, High, and a 2 Hz flashing mode
4. Momentarily press the Power/Enable button to enable the laser.

The Laser On indicator will light when the button is pressed and the laser output will come on after a 2 second delay.

5.2. Adjusting the Laser Output Power

Pressing the Mode button will cycle through the three laser power settings:

- Low power is approximately 1 mW,
- High power is greater than 2.5 mW but not more than 5 mW, and
- Pulse mode will flash the laser on and off at the High power value at 2 Hz.

5.3. Turning the Laser Off

Momentarily press the Power/Enable button to disable the laser, but keep the unit powered on. The Laser On indicator will go out and the laser will be disabled. Note that in this mode, the laser will not charge. The HLS635 can be put into standby by holding the Power/Enable button for approximately 3 seconds. The HLS635 is in standby when the Power indicator is not lit. Standby should be used whenever possible maximize battery life if running on battery power.



IMPORTANT!



Battery charging only occurs when the laser is disabled.

Battery charging only occurs when the ambient temperature is above 50°F.

5.4. Charging the Unit

When starting from a completely drained battery, the unit takes about 1 to 1.5 hours to charge during that time, the green Charging LED will light. At the end of the charge cycle the LED will turn off. The unit can be left on the charger indefinitely to maintain the full charge. Periodically, the Charging LED may flash indicating that the unit is “topping off” the battery.

The rechargeable battery will slowly discharge over time even when not in use. To prevent this, it is safe to leave the unit plugged into the power adapter and allow the unit to self-charge periodically.

The HLS635 is powered by the DC connector any time it is attached. Battery power is only used when the DC connector is removed. DC power may be connected and disconnected while the HLS635 is being used without interruption.

5.4.1. Battery Discharging

The Power LED indicator will start to flash when the battery is low. After a period of time, if power is not reconnected or the unit turned off, the unit will turn off and the battery will be disconnected from all internal circuitry to prevent battery damage. The power adapter can be plugged in to continue use or charge the unit normally.

Chapter 6 Specifications

6.1. Handheld Source

Specification	Value
Wavelength (Min, Typ., Max)	625 nm, 635 nm, 640 nm
Operating Mode	LOW, HIGH, PULSE
CW Output Power (High/Low)	>2.5 mW/1 mW
Pulsed Output Power (High/Low)	>2.5 mW/~0 mW
Laser Class	3R
Pulse Frequency	2 Hz, 50% Duty Cycle
Battery Type	NiMH, 3.6 V
Battery Temp Limits	-20°C (-4°F) to 60°C (140°F)
Battery Storage Temp	5°C (40°F)
Battery Life (High Power)	12 Hrs. Max.
Battery Life (Standby)	~45 Days
Battery Charge Temp Range	10°C (50°F) to 38°C (100°F)
Maximum Charge Time	~100 Minutes
Fiber Connector	FC/PC
Output Fiber	SM600
DC Input Voltage	9 VDC, 2 A (9.2 VDC Max.)
Dimensions	5.33" x 2.74" x 0.94" (135.4 mm x 69.6 mm x 24 mm)



Warning



If the temperature of the HLS635 exceeds the battery limits, battery damage may occur.

When not in use, the HLS635 should be stored in a cool dry place.

The HLS635 battery cannot be charged below 10 °C (50 °F) or above 38 °C (100°F). The charging lamp will go out and charging will discontinue under these conditions.

6.2. Power Supply

Specification	Value +/- 10%
AC Adapter Input	100 - 240 VAC, 0.48 A, 50 - 60 Hz
Max Power	18 W Max
Output Voltage	9 VDC, 2.2 A

Chapter 7 Mechanical Drawing

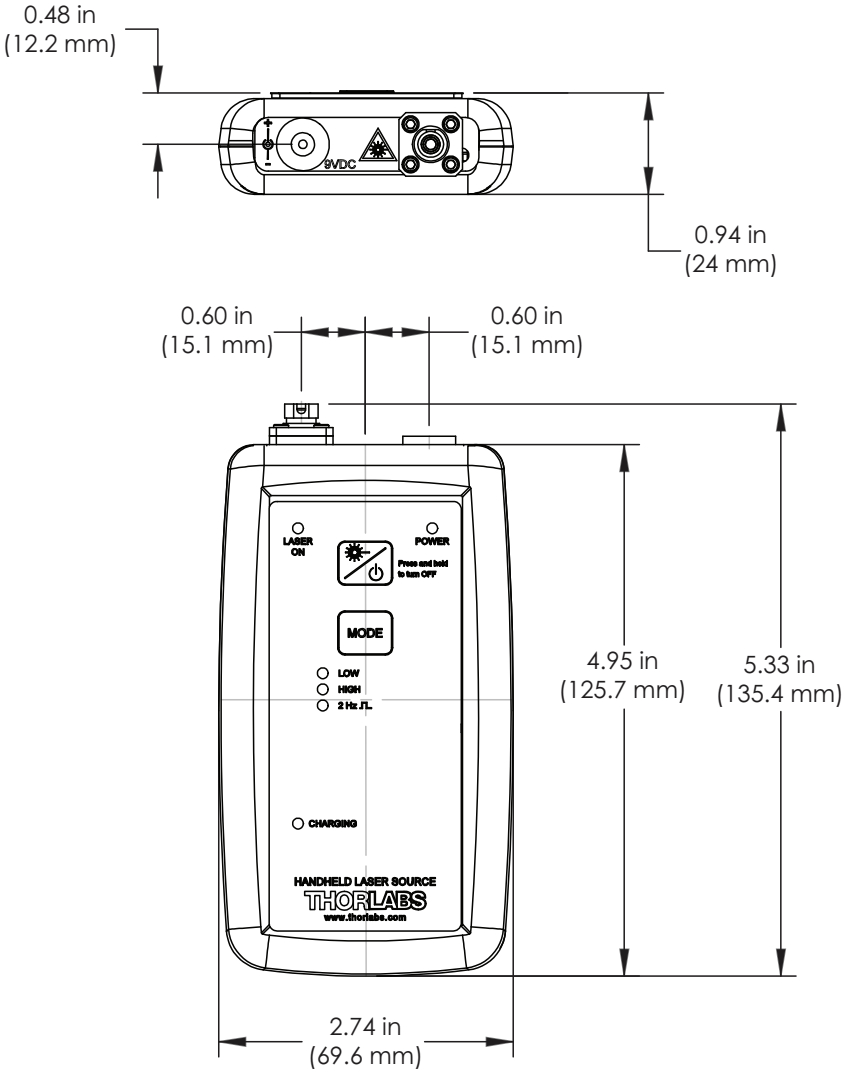

Chapter 8 Troubleshooting and Cleaning

Once it is set up, the HLS635 is easy to operate and provides many hours of use. In case you experience any problems, below are a few checks to help in troubleshooting the problem. If you have any questions, please contact your local Tech Support office.

Failure	Trouble Shooting Steps
Power Will Not Turn On	Check that the POWER/ENABLE button is held for at least 2 seconds.
	Connect DC power to make sure the battery is not completely drained.
Laser Will Not Enable	Momentarily press the POWER/ENABLE button.
	Wait at least 2 seconds after the LASER ON indicator lights.
	Check the output with a calibrated power meter.
Charging Does Not Start	Verify the power cable is properly connected.
	Verify the battery is not currently in a maximum charged state.
	Ambient temperature must be between 10 °C (50 °F) and 38 °C (100 °F).
	Make sure the laser is not enabled.

Cleaning

The unit can be cleaned using a soft, slightly damp cloth. Avoid using any solvents on or near the unit.

Chapter 9 Regulatory

As required by the WEEE (Waste Electrical and Electronic Equipment Directive) of the European Community and the corresponding national laws, Thorlabs offers all end users in the EC the possibility to return “end of life” units without incurring disposal charges.

- This offer is valid for Thorlabs electrical and electronic equipment:
- Sold after August 13, 2005
- Marked correspondingly with the crossed out “wheelie bin” logo (see right)
- Sold to a company or institute within the EC
- Currently owned by a company or institute within the EC
- Still complete, not disassembled and not contaminated

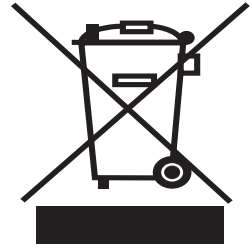

Wheelie Bin Logo

As the WEEE directive applies to self-contained operational electrical and electronic products, this end of life take back service does not refer to other Thorlabs products, such as:

- Pure OEM products, that means assemblies to be built into a unit by the user (e.g. OEM laser driver cards)
- Components
- Mechanics and optics
- Left over parts of units disassembled by the user (PCB's, housings etc.).

If you wish to return a Thorlabs unit for waste recovery, please contact Thorlabs or your nearest dealer for further information.

9.1. Waste Treatment is Your Own Responsibility

If you do not return an “end of life” unit to Thorlabs, you must hand it to a company specialized in waste recovery. Do not dispose of the unit in a litter bin or at a public waste disposal site.

9.2. Ecological Background

It is well known that WEEE pollutes the environment by releasing toxic products during decomposition. The aim of the European RoHS directive is to reduce the content of toxic substances in electronic products in the future.

The intent of the WEEE directive is to enforce the recycling of WEEE. A controlled recycling of end of life products will thereby avoid negative impacts on the environment.

Chapter 10 Certificate of Conformance

Konformitätserklärung Declaration of Conformity Déclaration de Conformité

**Thorlabs Inc
56 Sparta Ave.
Newton, NJ
USA**

erklärt in alleiniger Verantwortung, dass das Produkt:
declares under it's own responsibility, that the product:
déclare sous notre seule responsabilité, que le produit:

HLS635

mit den Anforderungen der Normen
fulfills the requirements of the standard
satisfait aux exigences des normes

2006/95 EC	Low Voltage Directive 12.Dec. 2006
EMC 2004/108/EC	Electromagnetic Compatibility Directive
EN 61010-1:2001	Safety of Test and Measurement Equipment
EN 61326-1:2006	EMC of Test and Measurement Equipment
CISPR 11 Edition 4:2003	Conducted Emissions
CISPR 11 Edition 4:2003	Radiated Emissions
IEC 61000-3-2,	Harmonics
IEC 61000-3-3	Voltage Fluctuation and Flicker
IEC 61000-4-2	Electrostatic Discharge
IEC 61000-4-3	Radiated Immunity
IEC 61000-4-4	Electrical Fast Transient/Burst, Power Leads
IEC 61000-4-4	Electrical Fast Transient/Burst, I/O Leads
IEC 61000-4-5	Surge Immunity, Power Leads
IEC 61000-4-6	Conducted Immunity, Power Leads
IEC 61000-4-6	Conducted Immunity, I/O Leads
IEC 61000-4-11	Voltage Dips, Interrupts and Variations

übereinstimmt und damit den Bedingungen entspricht.
and therefore corresponds to the regulations of the directive.
et répond ainsi aux dispositions de la directive.

Dachau, 27. Februar 2012

.....
D. J. J. J.

Ort und Datum der Ausstellung
Place and date of issue
Lieu et date d'établissement

Name und Unterschrift des Befugten
Name and signature of authorized person.
Nom et signature de la personne autorisée

Chapter 11 Thorlabs Worldwide Contacts

For technical support or sales inquiries, please visit us at www.thorlabs.com/contact for our most up-to-date contact information.



USA, Canada, and South America

Thorlabs, Inc.
sales@thorlabs.com
techsupport@thorlabs.com

UK and Ireland

Thorlabs Ltd.
sales.uk@thorlabs.com
techsupport.uk@thorlabs.com

Europe

Thorlabs GmbH
europe@thorlabs.com

Scandinavia

Thorlabs Sweden AB
scandinavia@thorlabs.com

France

Thorlabs SAS
sales.fr@thorlabs.com

Brazil

Thorlabs Vendas de Fotônicos Ltda.
brasil@thorlabs.com

Japan

Thorlabs Japan, Inc.
sales@thorlabs.jp

China

Thorlabs China
chinasales@thorlabs.com



THORLABS

www.thorlabs.com
