Operation Manual
Thorlabs Blueline™ Series
Laser Diode Controller

LDC2xx



2004

Version: 2.12
Date: 22.01.2004

Contents	page
1 General description of the laser diode controller LDC2xx	1
1.1 Packing List	1
1.2 Safety	1
1.3 Warranty	3
1.4 Features	4
1.5 Technical data	6
1.5.1 Common Data	6
1.5.2 Individual data LDC200VCSEL	7
1.5.3 Individual data LDC201ULN	8
1.5.4 Individual data LDC202	9
1.5.5 Individual data LDC205	10
1.5.6 Individual data LDC210	11
1.5.7 Individual data LDC220	12
1.6 Ordering codes and accessories	13
1.7 Operating elements	14
1.7.1 Operating elements on front panel	14
1.7.2 Operating elements on rear panel	16
1.8 Pre-settings	17
1.9 Connecting components	18
1.9.1 9-pole SUB-D output jack	18
1.9.2 Interlock and control LED for LASER ON	19
1.9.3 Connecting the laser diode and photodiode	20
1.9.4 Analog control output for the laser current	22
2 Operating the LDC2xx	23
2.1 Setting the current limit "LIM"	23
2.2 Selecting the laser diode polarity	23
2.3 Constant current mode (CONST I)	25
2.4 Constant power mode (CONST P)	26
2.4.1 Changing the "IPD" setting range	28
2.5 Calibrating the optical power display	29
2.6 Analog modulation of the laser diode	29
3 Remote control	31
4 Maintenance	32
4.1 Line voltage	32
4.2 Replacing the mains fuse	32
4.3 General care	33

4.4 Cleaning	34
4.5 Repair	34
4.6 Troubleshooting	35
5 Service	37
5.1 Line Voltage Setting	37
5.2 Internal Fuse Replacement	38
6 Listings	39
6.1 List of acronyms	39
6.2 List of figures	39
6.3 Certifications and compliances	40
6.4 Addresses	42

We aim to develop and produce the best solution for your application in the field of optical measurement technique. To help us to live up to your expectations and develop our products permanently we need your ideas and suggestions. Therefore, please let us know about possible criticism or ideas. We and our international partners are looking forward to hearing from you.

Thorlabs GmbH

This part of the instruction manual contains all the specific information on how to operate a current module LDC2xx. A general description is followed by explanations on how to operate the unit manually. You will also find information about a simple remote control of the unit.

Attention

This manual contains “WARNINGS” and “ATTENTION” labels in this form, to indicate personal danger or possible damage to equipment.

Please read these advises carefully!

NOTE

This manual also contains “NOTES” and “HINTS” written in this form.

1 General description of the laser diode controller LDC2xx

1.1 Packing List

1. 1 LDC2xx
2. 1 power cord, connector according to ordering country
3. 1 operation manual
4. 1 Connection cable CAB 400

1.2 Safety

Attention

All statements regarding safety of operation and technical data in this instruction manual will only apply when the unit is operated correctly.

Before applying power to your LDC2xx system, make sure that the protective conductor of the 3 conductor mains power cord is correctly connected to the protective earth contact of the socket outlet! Improper grounding can cause electric shock with damages to your health or even death!

Also make sure that the line voltage setting marked on the rear panel agrees with your local supply and that the corresponding fuses are inserted. If not, please have a service technician change the voltage (see section 5.1 Line Voltage Setting).

Changing of the mains fuse can be done by the customer (see section 4.2, Replacing the mains fuse)

The unit must not be operated in explosion endangered environments!

Laser and photodiodes must only be connected with duly shielded connection cables.

Only with written consent from Thorlabs GmbH may changes to single components be carried out or components not supplied by Thorlabs GmbH be used.

This precision device is only dispatchable if duly packed into the complete original packaging including the plastic form parts. If necessary, ask for a replacement package.

Attention

Laser modules can deliver up to several 100mW of (maybe) invisible laser radiation!

When operated incorrectly, this can cause severe damage to your eyes and health!

Be sure to pay strict attention to the safety recommendations of the appropriate laser safety class!

This laser safety class is marked on your external laser source used.

Attention

Mobile telephones, handy phones or other radio transmitters are not to be used within the range of three meters of this unit since the electromagnetic field intensity may then exceed the maximum allowed disturbance values according to EN 50 082-1.

1.3 Warranty

Thorlabs GmbH warrants material and production of the LDC2xx for a period of 24 months starting with the date of shipment. During this warranty period *Thorlabs GmbH* will see to defaults by repair or by exchange if these are entitled to warranty.

For warranty repairs or service the unit must be sent back to *Thorlabs GmbH (Germany)* or to a place determined by *Thorlabs GmbH*. The customer will carry the shipping costs to *Thorlabs GmbH*, in case of warranty repairs *Thorlabs GmbH* will carry the shipping costs back to the customer.

If no warranty repair is applicable the customer also has to carry the costs for back shipment.

In case of shipment from outside EU duties, taxes etc. which should arise have to be carried by the customer.

Thorlabs GmbH warrants the hard- and software determined by *Thorlabs GmbH* for this unit to operate fault-free provided that they are handled according to our requirements. However, *Thorlabs GmbH* does not warrant a fault free and uninterrupted operation of the unit, of the soft- or firmware for special applications nor this instruction manual to be error free. *Thorlabs GmbH* is not liable for consequential damages.

Restriction of warranty

The warranty mentioned before does not cover errors and defects being the result of improper treatment, software or interface not supplied by us, modification, misuse or operation outside the defined ambient stated by us or unauthorized maintenance.

Further claims will not be consented to and will not be acknowledged. *Thorlabs GmbH* does explicitly not warrant the usability or the economical use for certain cases of application.

Thorlabs GmbH reserves the right to change this instruction manual or the technical data of the described unit at any time.

1.4 Features

The laser diode controllers of the series LDC200 by [Thorlabs GmbH](#) are extremely precise controllers for laser diodes and LEDs. If a temperature controller by [Thorlabs GmbH](#) is used additionally the injection current or the optical output power and the temperature of the connected laser diode can be controlled simultaneously

To protect the laser diode against damage the LDC2xx provides the following protection circuits:

- **Softstart function**
- **Adjustable limitation of injection current**
- **Interlock (open circuit monitoring of the laser diode mount connection)**
- **Electronic shortcircuit for the laser diode in off-mode**
- **Separate key to switch the laser diode current on and off**
- **Monitoring LED for LASER ON mode**

The LDC2xx is easy to use due to the clearly structured front panel.

Operating parameters are shown on an illuminated 4½-digit LCD display. The parameter to be displayed is selected with a toggle switch.

The switch on/off delay and the softstart function protect the laser diode against undesired transients.

An independent hardware limit for the injection current can be set with a 20-turn potentiometer. This protects the laser diode against operating errors.

With the output open the laser diode is shortcircuited electronically so no voltage is applied to the laser diode.

When turned on the laser diode controller LDC2xx is automatically in LASER OFF mode. The laser current can be switched on/off with a separate key at the front panel.

Laser diode and photodiode are connected by a 9-pin D-sub jack at the rear of the unit. The output for the laser diode and the input for the photodiode are bipolar, thus all polarities of commercial available laser diodes can be connected.

With a control signal at the output jack an external LED can be used to indicate LASER ON.

The injection current or the optical output power of the laser diode can be modulated via a modulation input at the rear of the unit.

For monitoring purposes a voltage proportional to the laser diode current is provided at an analog control output at the rear.

If an error occurs or the limit for the laser current is reached, the corresponding LED lights up and a short beep gives a warning.

The installed mains filter and careful transformer shielding provide low ripple and noise at the output.

The internal cooling of the LDC200 with a fan protects the unit against overheating in case of high environmental temperatures.

With free air circulation a safe operation of the unit is guaranteed up to 40 °C ambient temperature.

Attention

Do not obstruct the air-ventilation slots in the housing!

If a laser diode head and the corresponding cable (CAB 400) by [Thorlabs GmbH](#) is used, damages caused by wrong connections are impossible.

1.5 Technical data

1.5.1 Common Data

(All technical data are valid at $23 \pm 5^\circ\text{C}$ and $45 \pm 15\%$ humidity)

Connectors:

Laser diode, photodiode, LD ON signal, interlock (0 ... 5 V) LD OUTPUT	9-pin D-Sub-jack
Modulation input (-10 V ... +10 V) MOD IN	BNC
Control output (0 ... 10 V) CTL OUT	BNC
Chassis ground	4 mm banana jack
Mains input	IEC 320

General data:

Line voltage	100 V / 115 V / 230 V (-10%, +15 %) (fixed)
Line frequency	50 ... 60 Hz
Power consumption (max.):	
	LDC200VCSEL 20VA
	LDC201ULN 20 VA
	LDC202 25 VA
	LDC205 30 VA
	LDC210 40 VA
	LDC220 60 VA

Supply mains overvoltage	Category II (Cat II)
Operating temperature ¹⁾	0 ... +40 °C
Storage temperature	-40°C ... +70 °C
Relative Humidity	Max. 80% up to 31 °C, decreasing to 50% at 40 °C
Pollution Degree (indoor use only)	2
Operation altitude	< 3000 m
Warm-up time for rated accuracy	10 min
Weight	≤ 3 kg
Dimensions W x H x D	147 x 73 x 317 mm ³

¹⁾ non condensing

1.5.2 Individual data LDC200VCSEL

Constant current mode:

Control range (continuously variable)	0 ... ± 20 mA
Setting accuracy	± 0.05 mA
Resolution	1 μ A
Accuracy	± 20 μ A
Compliance voltage	> 6 V
Noise (10 Hz ... 10 MHz, typ.)	$\ll 1.5$ μ A
Ripple (50 Hz, rms, typ.)	$\ll 1.5$ μ A
Transients (typ.)	< 20 μ A
Short-time fluctuations (15 s, 0 ... 10 Hz, typ.)	< 5 μ A
Temperature coefficient	≤ 50 ppm/ $^{\circ}$ C
Drift (30 min, 0 ... 10 Hz, typ.)	≤ 2 μ A

Constant power mode:

Control range photodiode current	5 μ A ... 2 mA
Setting accuracy	± 2 μ A
Resolution photodiode current	0.1 μ A
Resolution optical power	1 μ W

Laser current limit:

Setting range	0 ... > 20 mA
Setting accuracy	± 0.05 mA
Resolution	1 μ A

Analog modulation/voltage control:

Input resistance	10 k Ω
3dB-bandwidth (constant current)	DC ... 250 kHz
Modulation coefficient (CC)	2 mA/V $\pm 5\%$
Modulation coefficient (CP)	0.2 mA/V $\pm 5\%$

Control output (I_{LD}):

Load resistance	≥ 10 k Ω
Transfer coefficient	500 V/A $\pm 5\%$

1.5.3 Individual data LDC201ULN

Constant current mode:

Control range (continuously variable)	0 ... ± 100 mA
Setting accuracy	± 0.05 mA
Resolution	0.01 mA
Accuracy	± 50 μ A
Compliance voltage	> 2.5 V
Noise (10 Hz ... 10 MHz)	< 0.2 μ A
Ripple (50 Hz, rms)	< 0.5 μ A
Transients	< 50 μ A
Short-time fluctuations (15 s, 0 ... 10 Hz)	< 5 μ A
Temperature coefficient	≤ 50 ppm/ $^{\circ}$ C
Drift (30 min, 0 ... 10 Hz)	≤ 10 μ A

Constant power mode:

Control range photodiode current	5 μ A ... 2 mA
Setting accuracy	± 2 μ A
Resolution photodiode current	0.1 μ A
Resolution optical power	1 μ W

Laser current limit:

Setting range	0 ... > 100 mA
Setting accuracy	± 0.5 mA
Resolution	0.01 mA

Analog modulation/voltage control:

Input resistance	10 k Ω
3dB-bandwidth (constant current)	DC ... 3 kHz
Modulation coefficient (CC)	10 mA/V $\pm 5\%$
Modulation coefficient (CP)	0.2 mA/V $\pm 5\%$

Control output (I_{LD}):

Load resistance	≥ 10 k Ω
Transfer coefficient	100 V/A $\pm 5\%$

1.5.4 Individual data LDC202

Constant current mode:

Control range (continuously variable)	0 ... ± 200 mA
Setting accuracy	± 0.1 mA
Resolution	0.01 mA
Compliance voltage	> 6 V
Noise (10 Hz ... 10 MHz)	< 1.5 μ A
Ripple (50 Hz, rms)	< 1.5 μ A
Transients	< 200 μ A
Short-time fluctuations (15 s, 0 ... 10 Hz)	< 10 μ A
Temperature coefficient	≤ 50 ppm/ $^{\circ}$ C
Drift (30 min, 0 ... 10 Hz)	≤ 20 μ A

Constant power mode:

Control range photodiode current	5 μ A ... 2 mA
Setting accuracy	± 2 μ A
Resolution photodiode current	0.1 μ A
Resolution optical power	1 μ W

Laser current limit:

Setting range	0 ... > 200 mA
Setting accuracy	± 0.5 mA
Resolution	0.01 mA

Analog modulation/voltage control:

Input resistance	10 k Ω
Bandwidth (constant current)	DC ... 250 kHz
Modulation coefficient (CC)	20 mA/V $\pm 5\%$
Modulation coefficient (CP)	0.2 mA/V $\pm 5\%$

Control output:

Load resistance	≥ 10 k Ω
Transfer coefficient	50 V/A $\pm 5\%$

1.5.5 Individual data LDC205

Constant current mode:

Control range (continuously variable)	0 ... ± 500 mA
Setting accuracy	± 0.1 mA
Resolution	0.1 mA
Compliance voltage	> 4 V
Noise (10 Hz ... 10 MHz)	< 3 μ A
Ripple (50 Hz, rms)	< 2 μ A
Transients	< 500 μ A
Short-time fluctuations (15 s, 0 ... 10 Hz)	< 10 μ A
Temperature coefficient	≤ 50 ppm/ $^{\circ}$ C
Drift (30 min, 0 ... 10 Hz)	≤ 50 μ A

Constant power mode:

Control range photodiode current	5 μ A ... 2 mA
Setting accuracy	± 2 μ A
Resolution photodiode current	0.1 μ A
Resolution optical power	1 μ W

Laser current limit:

Setting range	0 ... > 500 mA
Setting accuracy	± 1.5 mA
Resolution	0.1 mA

Analog modulation/voltage control:

Input resistance	10 k Ω
Bandwidth (constant current)	DC ... 150 kHz
Modulation coefficient (CC)	50 mA/V $\pm 5\%$
Modulation coefficient (CP)	0.2 mA/V $\pm 5\%$

Control output:

Load resistance	≥ 10 k Ω
Transfer coefficient	20 V/A $\pm 5\%$

1.5.6 Individual data LDC210

Constant current mode:

Control range (continuously variable)	0 ... ± 1 A
Setting accuracy	± 1 mA
Resolution	0.1 mA
Compliance voltage	> 4 V
Noise (10 Hz ... 10 MHz)	< 5 μ A
Ripple (50 Hz, rms)	< 3 μ A
Transients	< 1 mA
Short-time fluctuations (15 s, 0 ... 10 Hz)	< 25 μ A
Temperature coefficient	≤ 50 ppm/ $^{\circ}$ C
Drift (30 min, 0 ... 10 Hz)	≤ 100 μ A

Constant power mode:

Control range photodiode current	5 μ A ... 2 mA
Setting accuracy	± 2 μ A
Resolution photodiode current	0.1 μ A
Resolution optical power	0.1 mW

Laser current limit:

Setting range	0 ... > 1 A
Setting accuracy	± 2.5 mA
Resolution	0.1 mA

Analog modulation/voltage control:

Input resistance	10 k Ω
Bandwidth (current control)	DC ... 100 kHz
Modulation coefficient (CC)	100 mA/V
Modulation coefficient (CP)	0.2 mA/V $\pm 5\%$

Control output:

Load resistance	≥ 10 k Ω
Transfer coefficient	10 V/A $\pm 5\%$

1.5.7 Individual data LDC220

Constant current mode:

Control range (continuously variable)	0 ... ± 2 A
Setting accuracy	± 2 mA
Resolution	0.1 mA
Compliance voltage	> 4 V
Noise (10 Hz ... 10 MHz)	< 15 μ A
Ripple (50 Hz, rms)	< 5 μ A
Transients	< 100 μ A
Short-time fluctuations (15 s, 0 ... 10 Hz)	< 2 mA
Temperature coefficient	≤ 50 ppm/ $^{\circ}$ C
Drift (30 min, 0 ... 10 Hz)	≤ 200 μ A

Constant power mode:

Control range photodiode current	5 μ A ... 2 mA
Setting accuracy	± 2 μ A
Resolution photodiode current	0.1 μ A
Resolution optical power	0.1 mW

Laser current limit:

Setting range	0 ... > 2 A
Setting accuracy	± 5 mA
Resolution	0.1 mA

Analog modulation/voltage control:

Input resistance	10 k Ω
Bandwidth (current control)	DC ... 50 kHz
Modulation coefficient (CC)	200 mA/V
Modulation coefficient (CP)	0.2 mA/V $\pm 5\%$

Control output:

Load resistance	≥ 10 k Ω
Transfer coefficient	10 V/A $\pm 5\%$

1.6 Ordering codes and accessories

<u>Ordering-code</u>	<u>Short description</u>
LDC200VCSEL	Laser diode controller, current range 0 ... 20 mA / 6 V
LDC201ULN	Laser diode controller, current range 0 ... 100 mA / 2.5 V Ultra Low Noise
LDC202	Laser diode controller, current range 0 ... 200 mA / 6 V
LDC205	Laser diode controller, current range 0 ... 500 mA / 4 V
LDC210	Laser diode controller, current range 0 ... 1 A / 4 V
LDC220	Laser diode controller, current range 0 ... 2 A / 4 V
	laser diode heads for different laser diode packages:
TCLDM9	Temperature controlled laser diode head for 3- and 4-pin TO18-packages (9 mm CD, 5.6 mm CD)
LM14S1	laser diode head for laser modules in a 14-pin butterfly-package (programmable pinning)
LM14A51	laser diode head for laser modules in a 14-pin butterfly-package (Laser pinning type 1, incl. Bias-T)
LM14A12	laser diode head for laser modules in a 14-pin butterfly-package (Laser pinning type 2)
LM14A21	laser diode head for laser modules in a 14-pin butterfly-package for pump lasers (2A LD and TEC current)
LM7C11	laser diode head for laser modules in a 7-pin butterfly-package
	Shielded cable:
CAB400	Cable to connect the laser diode controller LDC200 to a Laser Diode Head

1.7 Operating elements

1.7.1 Operating elements on front panel

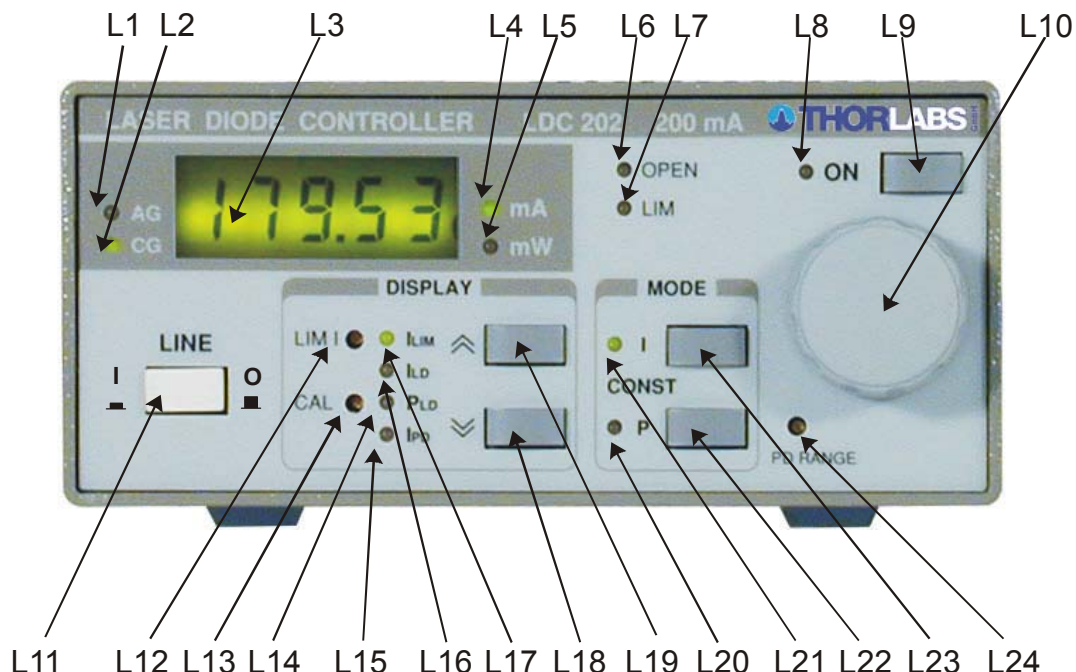

Figure 1 Display- and operating elements at the front panel

L1	LED "AG"	Selected polarity of the laser: anode grounded
L2	LED "CG"	Selected polarity of the laser: cathode grounded
L3		4½-digit LCD display
L4	LED "mA"	Current display in mA
L5	LED "mW"	Power display in mW
L6	LED "OPEN"	No laser diode connected
L7	LED "LIM"	Adjusted current limit reached
L8	LED "ON"	Laser current is switched on
L9	Switch "ON"	On/off switch for the laser current
L10		Knob to enter set values
L11		Mains switch
L12	LIM I	Potentiometer for setting the current limit
L13	CAL	Potentiometer for calibrating the power display
L14	LED "PLD"	Displaying the optical output power
L15	LED "IPD"	Displaying the photodiode current

L16	LED "ILD"	Displaying the laser current
L17	LED "ILIM"	Displaying current limit
L18	DOWN	Select the displayed value
L19	UP	Select the displayed value
L20	LED "P"	Constant power mode
L21	LED "I"	Constant current mode
L22	Key "P"	Select constant power mode
L23	KEY "I"	Select constant current mode
L24	PD RANGE	Potentiometer for setting the photodiode current range

1.7.2 Operating elements on rear panel

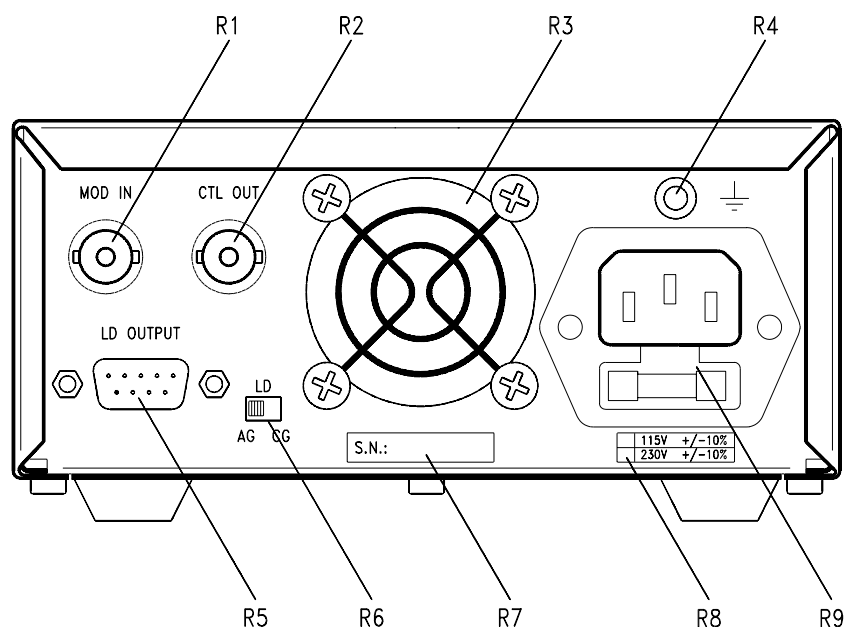

Figure 2 Operating elements on the rear panel

- R1** Modulation input/ analogue control input "MOD IN", -10V ... +10 V
- R2** Analogue control output "CTL OUT", 0 ... ± 10 V
- R3** Fan
- R4** Connector for chassis ground
- R5** Connector "LD OUT" for laser diode, photodiode, interlock, status-LED
- R6** Switch "LD POL" for selecting the laser diode polarity
- R7** Serial number of the unit
- R8** Letterplate showing allowed and set mains voltage ranges
- R9** Mains connector and fuse holder

1.8 Pre-settings

Prior to starting operation with a laser diode controller LDC2xx, check if the line voltage specified on the letterplate agrees with your local supply and if the appropriate fuse is inserted. (To change the line voltage see 4.1, “Line voltage” on page 32)

Connect the unit to the line with the provided mains cable. Turn the unit on by means of the line switch (L11).

Via the connector jack of the chassis ground (R4) the external optical build-up can be connected to ground potential, if required. The ground pin of the laser diode is internally connected to chassis ground.

After switching on the unit, the LCD display (L3) must get visible and a LED must light up indicating the selected parameters (L14 ... L17). If no display is shown please check line voltage and line fuse.

By using the keys (L18) and (L19) you can select the desired value to be displayed at any time.

The LDC2xx is immediately ready to use after turning on. The rated accuracy is reached, however, after a warming-up time of approx. 10 minutes.

1.9 Connecting components

1.9.1 9-pole SUB-D output jack

The laser diode controller LDC2xx by [Thorlabs GmbH](#) can (according to the version) drive all laser diodes up to a maximum current rate of 2 A.

If laser mounts by [Thorlabs GmbH](#) are used just connect the input "LD DRIVER" of the laser mount to the output jack "LD OUTPUT" (R5) with the cable CAB400.

If a laser mount TCLDM9 by [Thorlabs](#) is used, the polarity of laser diode and photodiode must additionally be set with two slide switches inside the laser mount (refer to the individual operation manual).

If other laser diode mounts are used connect the laser diode and if provided the photodiode with shielded cables to "LD OUTPUT" (R5) according to the pin assignment shown in Figure 3.

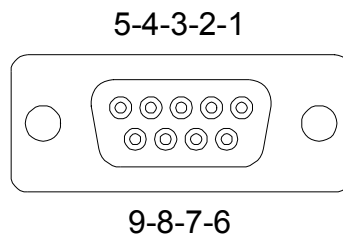

Figure 3 Pin assignment of the "LD OUTPUT"jack (female)

pin connection

open circuit monitoring, status display:

- 1** interlock and status LASER ON/OFF
- 5** digital ground for pin 1

laser diode:

- 7** laser diode cathode (at AG)
- 8** laser diode anode (at CG)
- 3** laser diode ground

photodiode:

- 2** photodiode cathode
- 4** photodiode anode

1.9.2 Interlock and control LED for LASER ON

Pin 1 and pin 5 of the "LD OUTPUT" jack (R5) are test contacts to determine whether a laser diode is connected or not or if the connection to the laser diode has been interrupted during operation.



Figure 4 Connecting the interlock with and without monitoring LED

Pin 1 and pin 5 must be connected externally by a wire (total resistance <math><430 \Omega</math>). When opening this connection, the LDC2xx switches automatically into LASER OFF mode.

A LED can be connected in parallel to a resistor of <math><470 \Omega</math> between pin 1 and pin 5. This LED lights up when the laser current is switched on (LASER ON).

1.9.3 Connecting the laser diode and photodiode

Connect laser diode and photodiode according to Figure 5 to the LDC2xx.

The ground connection of the laser diode (pin 3) may be connected to the anode of the photodiode (pin 4) or to the cathode of the photodiode (pin 2). This connection should be as close as possible to the laser diode to avoid measuring errors.

If the polarity selected with the switch "LD POL" (R6) and the connection of the laser diode do not agree, no current is flowing through the laser diode.

The laser diode is always sourced with respect to ground. Compared to a floating driver stage, this operation mode has the advantages of higher security for the laser diode and better stability of the laser current.

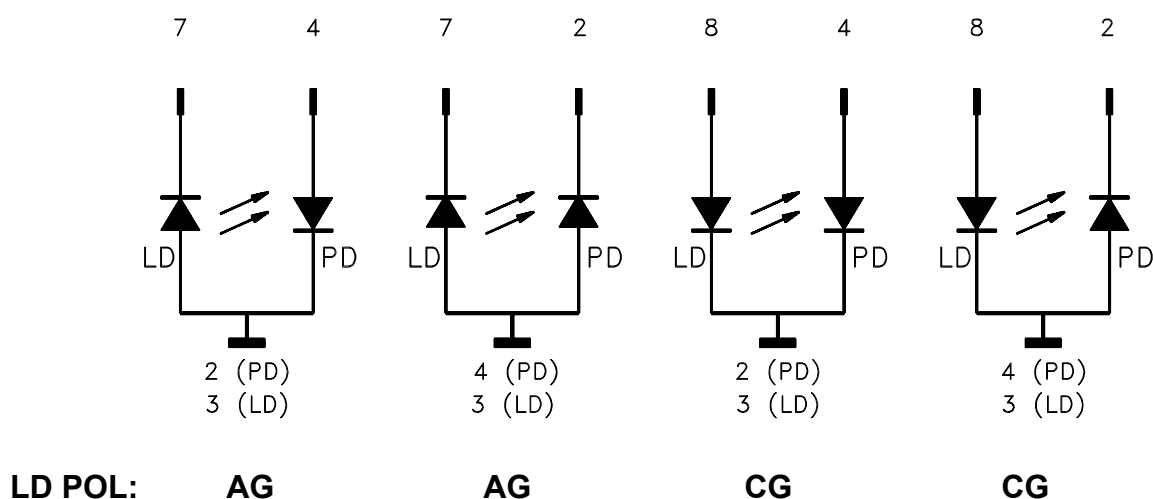
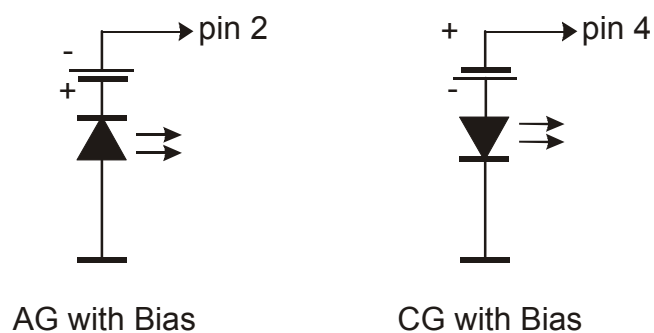

Figure 5 Connecting laser diode and photodiode

If the photodiode shall be operated with bias voltage a battery can be connected in series to the photodiode.

With polarity AG connect the positive terminal of the battery to the cathode of the photodiode and the negative terminal of the battery to pin 2.

With polarity CG connect the negative terminal of the battery to the anode of the photodiode and the positive terminal of the battery to pin 4.



Attention

A wrong polarity of the battery may destroy the photodiode due to a forward current flowing through it!

1.9.4 Analog control output for the laser current

At the output "CTL OUT" (R2) a voltage proportional to the laser current "ILD" is available.

E.g. a recorder, an oscilloscope or an A/D converter card can be connected directly to the output.

The output "CTL OUT" (R2) provides a voltage of $0 \dots \pm 10 \text{ V}$ for $I_{LD} = 0 \dots I_{LD \text{ MAX}}$.
With laser polarity "CG" the output voltage is positive ($0 \dots +10 \text{ V}$), with laser polarity "AG" the output voltage is negative ($0 \dots -10 \text{ V}$).

The output "CTL OUT" (R2) is grounded.

Devices connected to this output should have an input resistance $\geq 10 \text{ k}\Omega$.

When connecting a load avoid ground loops.

2 Operating the LDC2xx

2.1 Setting the current limit "ILIM"

Before operating a laser diode always set the limit for the injection current to protect the laser diode against destruction by operating errors.

Switch on the unit with the button "LINE" (L11).

If the unit had already been switched on before switch off the laser current with the key "ON" (L9).

Select parameter "ILIM" with the button (L18) or (L19).

Use a screwdriver to set the desired current with the potentiometer "LIM I" (L12).

NOTE:

The current limit can be displayed at any time by selecting the parameter "ILIM".

If the laser current reaches the set current limit "ILIM" during operation the LED "LIM" (L7) lights up and a short beep gives a warning.

The current limit can also be adjusted with the output switched on. In any case you should avoid an adjustment when the LED "LIM" (L7) lights up.

2.2 Selecting the laser diode polarity

With the laser diode controller LDC2xx all possible polarities of the laser diode and the monitor diode can be used. The laser diode will always be sourced with respect to ground. Compared to a floating driver stage this operation mode has the advantages of higher security for the laser diode and better stability and lower noise of the laser current.

Prior to turn on the laser current the correct polarity of the laser diode must be selected:

Switch off the LDC2xx.

Select the desired polarity with the switch "LD POL" (R6).

For laser diodes with a built-in monitor diode the common pin of laser diode and photodiode is the ground pin.

The selected polarity of the output is indicated with the LED "AG" (L1) or "CG" (L2).

For safety reasons there is a mid position of the switch "LD POL" (R6).

NOTE:

If the mid position of the switch "LD POL" (R6) is selected, neither the LED (L1) nor (L2) lights up. The laser current cannot be switched on.

If the laser diode is connected correctly (refer to chapter 1.9.3) but the polarity of the laser diode selected wrong with switch (R6) the laser diode current cannot be switched on.

If the position of the switch "LD POL" (R6) is changed with the laser current switched on the laser diode current is switched off automatically.

NOTE:

For safety reasons you should select the polarity for the laser diode only with the laser diode current switched off.

2.3 Constant current mode (CONST I)

Switch on the LDC2xx.

Select a suitable current limit "I_{LIM}" (refer to chapter 2.1).

Select the appropriate laser polarity (refer to chapter 2.2).

Connect the laser diode (refer to chapter 1.9.3).

Select the display "I_{LD}" with the button (L18) or (L19).

Set the adjust knob (L10) completely to the left.

Select constant current mode with key "I" (L23).

Switch on the output by pressing key "ON" (L9). The LED "ON" (L8) lights up, the output is activated and the current slowly rises (about 1 s) to the set value with knob (L10).

NOTE:

The current output can only be switched on if the jack "LD OUTPUT" (R5) is connected correctly.

The display shows the injection current "I_{LD}".

With the adjust knob (L10) the laser current can be set continuously between 0 mA and the selected current limit "I_{LIM}".

If the injection current "I_{LD}" reaches the set current limit "I_{LIM}" during operation the LED "LIM" (L7) lights up, a short beep as warning signal is heard and the laser current is limited to the value of the current limit "I_{LIM}".

If the LED "LIM" (L7) lights up noise and ripple do not longer correspond to the specifications for normal operation (refer to chapter 1.5). However exceeding the set current limit "I_{LIM}" is not possible.

If the connection to the laser diode is interrupted during operation the laser diode current is switched off automatically. LED "ON" (L8) extinguishes, LED "OPEN" (L6) lights up and a short beep is heard as warning signal.

If the output is switched on while the interlock is closed and there is no laser diode connected at first the LED "ON" (L8) lights up and the output is switched on. Immediately afterwards the LDC2xx recognizes the missing of the laser diode and switches the output off.

The LED "ON" (L8) extinguishes and the LED "OPEN" (L6) lights up.

After pressing "ON" (L9) the LED "OPEN" (L6) extinguishes and the output can be switched on again by pressing "ON" (L9).

If a photodiode is connected the display can show the photodiode current " I_{PD} " or the optical power "PLD" by pressing the keys (L18) or (L19).

The laser current can be modulated via the connector "MOD IN" (R3) (refer to chapter 2.6).

2.4 Constant power mode (CONST P)

With a photodiode connected the laser diode can also be operated in constant power mode:

Start operating the LDC2xx in constant current mode (refer to chapter 2.3)

Select the display " I_{PD} " with the buttons (L18) or (L19).

Check whether an appropriate laser diode current " I_{PD} " is available. A photodiode current of at least 5 μ A must be available for a stable operation of the power control.

NOTE:

With negative signs of the photodiode current " I_{PD} " the photodiode must be reverse connected.

By pressing "ON" (L9) switch off the laser current.

Select constant power (CONST P) with "P" (L22).

Set the adjust knob (L10) completely to the left.

Switch on the output by pressing "ON" (L9). The LED "ON" (L8) lights up, the output is activated and the current slowly increases (about 1 s) to the value set with the knob (L10).

With the knob (L10) you can continuously set the photodiode current " I_{PD} " and thus the optical power of the laser diode until the laser current " I_{LD} " reaches the selected current limit " I_{LIM} ".

If the desired photodiode current " I_{PD} " cannot be set exactly enough with the knob (L10), the range of the knob (L10) can be adapted to the provided photodiode current in wide ranges with the potentiometer "PD RANGE" (L24).

If no photodiode is connected or the polarity of the photodiode is set wrong (refer to chapter 2.2), the laser current " I_{LD} " increases to the set current limit " I_{LIM} " after the output is switched on.

If the photodiode current " I_{PD} " is interrupted in constant power mode, the laser current " I_{LD} " increases to the set current limit " I_{LIM} ".

If the injection current " I_{LD} " is limited by the selected current limit " I_{LIM} " ripple and noise do no longer correspond to the specifications for normal operation. However, the set maximum current " I_{LIM} " cannot be exceeded.

If the connection to the laser diode is interrupted during operation the output is switched off automatically. LED "ON" (L8) extinguishes, LED "OPEN" (L6) lights up and a short beep is heard as warning.

If the output is switched on while the interlock is closed and there is no laser diode connected, at first the LED "ON" (L8) lights up and the output is switched on. Immediately afterwards the LDC2xx recognizes the missing of the laser diode, switches the output off, the LED "ON" (L8) extinguishes and the LED "OPEN" (L6) lights up.

After pressing "ON" (L9) the LED "OPEN" (L6) extinguishes and the laser diode current output can be switched on again by pressing "ON" (L9).

The laser current can be modulated via the connector "MOD IN" (R3) (refer to chapter 2.6).

2.4.1 Changing the " I_{PD} " setting range

To guarantee an easy setting of the operating point in constant power mode even with small photodiode currents the full scale of the adjustment knob (L10) can be set with potentiometer "PD RANGE" (L24) between 0.6 mA and 2 mA.

Turn the potentiometer "PD RANGE" (L24) completely to the left (i.e. full scale = 0.6 mA).

Turn the adjust knob (L10) completely to the left.

Select constant power mode CONST P, connect the laser diode and the photodiode and switch on the laser current.

Set the desired photodiode current with the knob (L10).

If the desired operating point cannot be reached even if the knob (L10) is turned completely to the right (i.e. $I_{PD} > 0.6$ mA), turn the potentiometer "PD RANGE" (L24) to the right until the desired setting range has been reached.

NOTE:

Changing the position of the potentiometer "PD RANGE" (L24) changes the set value in constant power mode. In constant current mode the potentiometer "PD RANGE" is without function.

2.5 Calibrating the optical power display

Additional to the photodiode current "IPD" also the optical power of the laser diode can be displayed. The actual optical power is shown only after calibration of the power display. For calibration the potentiometer "CAL PD" (L13) is used.

Select constant current mode CONST I.

With the knob (L10) either set a laser current "ILD" or a monitor current "IPD" where the optical output power of the laser diode is known, e.g. from the data sheet of the laser diode. The better way is to measure the laser power with an external optical power meter.

Select the display "PLD" (L5) with the keys (L18) or (L19).

Calibrate the display "PLD" with potentiometer "CAL PD" (L13) to the value of the actual optical power.

2.6 Analog modulation of the laser diode

To generate a time dependent injection current "ILD" or photodiode current "IPD" these settings can be modulated via an independent ground-symmetric modulation input "MOD IN" (R1). Maximum allowed input voltage is $-10\text{ V} \dots +10\text{ V}$, input resistance $>10\text{ k}\Omega$.

"ILD" and "IPD" are calculated as:

$$ILD = ILD\text{ SET} + I_{MAX} * U_{MOD} / 10\text{ V}$$

or $IPD = IPD\text{ SET} + 0.2\text{ mA} * U_{MOD}$

with:

ILD SET or IPD SET: value set with (L10)

UMOD: voltage at "MOD IN" (R1)

Start operation in constant current or constant power mode (refer to chapter 2.3 or 2.4) and adjust the desired set value with the knob (L10).

Connect the modulation source to the jack "MOD IN" (R1). Avoid ground loops when connecting the function generator.

The laser diode current "LD" can be supervised at the analog output "CTL OUT" (R2) (refer to chapter 1.9.4).

If the injection current "LD" reaches the set current limit "LIM" in operation the LED "LIM" (L7) lights up, a beep is given as short warning signal and the laser current is limited to the value of the current limit "LIM".

If the injection current "LD" is limited by the selected current limit "LIM" ripple and noise do no longer correspond to the specifications for normal operation (refer to chapter 1.5). However the set maximum current "LIM" cannot be exceeded.

3 Remote control

The units of the LDC200 series do not provide any standard computer interface. By using the analog inputs and outputs however simple semi-automatic systems may be build up.

The following control or read back functions are possible:

Interlock

If a relay contact or an open collector transistor is inserted in the interlock line (refer to chapter 1.9.2), the output can be switched off automatically at any time.

An automatic reactivation however is not possible.

Setting the laser diode current

If the adjusting knob (L10) is set to the left stop the set laser diode current value can be controlled with an analog voltage of 0 ...+10 V at the "MOD IN"-input, R1. If L10 is at his right stop, you can also use a control voltage of -10 V ... 0 V.

Thus a setting via D/A converter is easily possible. Input resistance of L10 is >10 k Ω

Monitoring the laser current

If an A/D converter is connected to the output "CTL OUT" (R2) the laser current can easily be monitored. Output voltage is 0 ... \pm 10 V, 0 ...+10 V with cathode grounded, 0 ... -10 V with anode grounded. Load resistance should be >10 k Ω .

NOTE

All operating elements of the LDC2xx are active at any time. For automatic tests make sure that the manual settings are not changed during operation.

4 Maintenance

4.1 Line voltage

The laser diode controller LDC200 operates at fixed line voltages of 90 V ... 115 V, 104 V ... 132 V or 207 V ... 264 V. Prior to starting operation check that the line voltage specified on the letterplate agrees with your local supply. A qualified service person is required to change the operating Line voltage. See section 5 (Service) for instructions.

4.2 Replacing the mains fuse

If the mains fuse has opened due to line distortions, incorrect line voltage or other causes, it can be easily replaced from the rear without opening the unit.

Attention

To avoid risk of fire only the appropriate fuse for the corresponding line voltage must be used.

1. Turn off the LDC2xx and disconnect the mains cable.
2. Open the fuse drawer in the mains connector R9 (see Figure 6) with a screwdriver.
3. Replace the defective fuse (one spare fuse is included in the fuse holder) and close the drawer.

LDC200VCSEL, LDC201ULN and LDC202:

100 V	250 mA, Slow, 250V	T0.25A250V
115 V	250 mA, Slow, 250V	T0.25A250V
230 V	160 mA, Slow, 250V	T0.16A250V

LDC205, LDC210 and LDC220:

100 V	500 mA, Slow, 250V	T0.5A250V
115 V	500 mA, Slow, 250V	T0.5A250V
230 V	250 mA, Slow, 250V	T0.25A250V

All fuses are to be IEC 60127-2/III

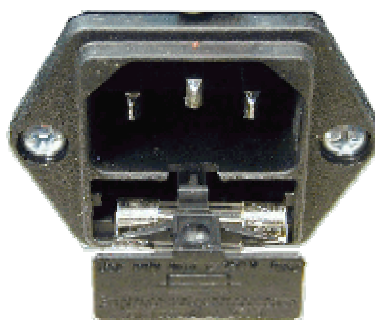

Figure 6 Changing the mains fuse

4.3 General care

Protect the LDC2xx from adverse weather conditions. The LDC2xx is not water resistant.

Do not store or leave the LDC2xx where the LCD display will be exposed to direct sunlight for long periods of time.

Attention

To avoid damage to the LDC2xx, do not expose it to spray, liquids or solvents!

4.4 Cleaning

The unit and the LCD display can be cleaned with a cloth dampened with water. You can use a mild 75% Isopropyl Alcohol solution for more efficient cleaning.

4.5 Repair

The LDC2xx does not contain any modules that can be repaired by users.

To guarantee the specifications given in chapter 1.5 over a long period it is recommended to have the unit calibrated by [Thorlabs GmbH](#) every two years.

4.6 Troubleshooting

In case that your LDC200 system shows malfunction please check the following items:

◆ Module does not work at all (no display on the mainframe):

- Mainframe LDC200 connected properly to the mains?
 - Connect the LDC200 to the power line paying attention to the right voltage setting of your mainframe.
- Mainframe LDC200 turned on?
 - Turn on your LDC200 with the key mains-switch.
- Control the fuse at the rear panel of the LDC200 mainframe.
 - If blown up replace the fuse by the correct type

◆ You don't get the desired laser output power

- Is the interlock closed?
 - Control the resistance between the interlock pins of the connector jack not to be more than 430 Ω .
 - ➔ (refer to section 1.9.2, "Interlock and control LED for LASER ON" on page 19)
- Do you have turned on the laser output with the "ON" button?
 - Change the setting from "off" to "on".
 - ➔ The LED "ON" on the front panel of the mainframe must be on
- Is the current limit I_{LIM} set to 0?
 - Adjust the hardware limit I_{LIM} by means of the potentiometer on the LDC2xx front panel to an appropriate value.

- Is the laser diode installed properly?
 - Control the connection cable.

- Is the laser diode polarity set correctly?
 - If not change the polarity of the diode or set the polarity switch at the LDC2xx to opposite polarity.

- Is the photo diode connected properly?
 - Check the connecting cable.

- Is the photo diode poled correctly?
 - If in constant power mode the displayed photodiode current is negative you must revert the polarity of the photodiode.

- Are you using a bias voltage with the photo diode in photocurrent mode?

Change the polarity of the diode for photo element mode or change the polarity of the bias voltage source.

- Is the desired output power programmed correctly?
 - Adjust the desired output power P_{LD} with the tuning knob.

If you don't find the error source by means of the trouble shooting list please first contact the [Thorlabs GmbH-Hotline \(blueline@thorlabs.com\)](mailto:blueline@thorlabs.com) before sending the LDC200 for checkup and repair to [Thorlabs GmbH](#) - Germany.

(refer to section 6.4, "Addresses " on page 42)

5 Service

5.1 Line Voltage Setting

The Line voltage setting can be changed only by qualified service personnel. Only qualified service personnel should perform service procedures.

Disconnect Power. To avoid electrical shock, first switch off the LDC2xx power, and then disconnect the power cord from the mains power.

With the LDC2xx turned over, remove the two screws that secure the cover to the chassis. One of the screws has a paint piercing washer.

Remove the unit by sliding it out of the cover. With the unit set upright, you will find the range switch near the front of the unit, next to the transformer (see Figure 8)

Using a flat-blade screwdriver, turn the switch to the desired range by aligning the triangle with the appropriate voltage (100V, 115V, or 230V +15%, -10% each). Ensure that the switch has clicked into one of the three positions and is not between positions.

On the back of the instrument, remove the indicator screw from the old location and install it in the location corresponding to the new range setting.

Attention

If you have changed to or from 230 V, also change the mains fuse to the correct value given in section 4.2 of this manual.!

Reattach the cover, ensuring that the paint piercing screw is in the original location.

5.2 Internal Fuse Replacement

Internal fuses must be changed only by qualified service personnel.

Open the unit like described in section 5.1.

Depending on the type of LDC2xx, you will find adhesive labels on the transformer depicting type and location of the internal fuses.

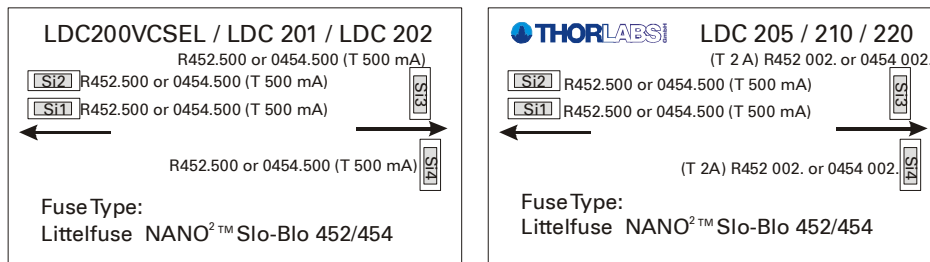

Figure 7 Label 'Internal fuses'

Use only fuses of the type 'Littelfuse NANO²™ Slo-Blo Fuse 452/454 Series'.

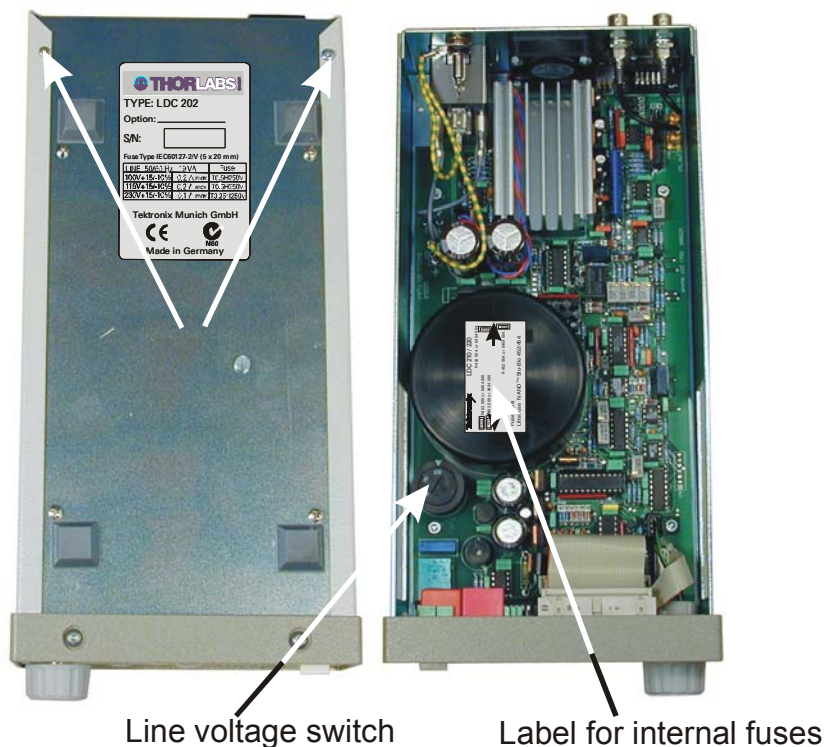

Figure 8 Setting the line voltage

Replace the defective fuse and close the unit again (see section 5.1).

6 Listings

6.1 List of acronyms

The following acronyms are used in this manual:

AC	<u>A</u> lternating <u>C</u> urrent
ADC	<u>A</u> nalog to <u>D</u> igital <u>C</u> onverter
AG	<u>A</u> node <u>G</u> round
CC	<u>C</u> onstant <u>C</u> urrent mode
CG	<u>C</u> athode <u>G</u> round
CP	<u>C</u> onstant <u>P</u> ower mode
DAC	<u>D</u> igital to <u>A</u> nalog <u>C</u> onverter
DC	<u>D</u> irect <u>C</u> urrent
LD	<u>L</u> aser <u>D</u> iode
LDC	<u>L</u> aser <u>D</u> iode <u>C</u> ontroller
LED	<u>L</u> ight <u>E</u> mitting <u>D</u> iode
LS	<u>L</u> aser <u>S</u> ource Module
OTP	<u>O</u> ver <u>T</u> em <u>P</u> erature
PD	<u>P</u> hoto <u>D</u> iode
TEC	<u>T</u> hermo <u>E</u> lectric <u>C</u> ooler (Peltier Element)

6.2 List of figures

Figure 1	Display- and operating elements at the front panel	14
Figure 2	Operating elements on the rear panel	16
Figure 3	Pin assignment of the "LD OUTPUT"jack (female)	19
Figure 4	Connecting the interlock with and without monitoring LED	19
Figure 5	Connecting laser diode and photodiode	20
Figure 6	Changing the mains fuse	33
Figure 7	Label 'Internal fuses'	38
Figure 8	Setting the line voltage	38

6.3 Certifications and compliances

Certifications and compliances

Category	Standards or description	
EC Declaration of Conformity - EMC	Meets intent of Directive 89/336/EEC for Electromagnetic Compatibility. Compliance was demonstrated to the following specifications as listed in the Official Journal of the European Communities:	
	EN 61326	EMC requirements for Class A electrical equipment for measurement, control and laboratory use, including Class A Radiated and Conducted Emissions ^{1,2,3} and Immunity. ^{1,2,4}
	IEC 61000-4-2	Electrostatic Discharge Immunity (Performance criterion C)
	IEC 61000-4-3	Radiated RF Electromagnetic Field Immunity (Performance criterion B) ⁵
	IEC 61000-4-4	Electrical Fast Transient / Burst immunity (Performance criterion C)
	IEC 61000-4-5	Power line Surge Immunity (Performance criterion C)
	IEC 61000-4-6	Conducted RF Immunity (Performance criterion B)
	IEC 61000-4-11	Voltage Dips and Interruptions Immunity (Performance criterion C)
	EN 61000-3-2	AC power line harmonic emissions
Australia / New Zealand Declaration of Conformity - EMC	Complies with the Radiocommunications Act and demonstrated per EMC Emission standard ^{1,2,3} :	
	AS/NZS 2064	Industrial, Scientific, and Medical Equipment: 1992
FCC EMC Compliance	Emissions comply with the Class A Limits of FCC Code of Federal Regulations 47, Part 15, Subpart B ^{1,2,3} .	

¹ Compliance demonstrated using high-quality shielded interface cables.

² Compliance demonstrated with CAB400 cable installed at the LD Output port.

³ Emissions, which exceed the levels required by these standards, may occur when this equipment is connected to a test object.

⁴ Minimum Immunity Test requirement.

⁵ MOD IN port capped at IEC 61000-4-3 test.

Certifications and compliances

Category	Standards or description	
EC Declaration of Conformity - Low Voltage	Compliance was demonstrated to the following specification as listed in the Official Journal of the European Communities: Low Voltage Directive 73/23/EEC, amended by 93/68/EEC	
	EN 61010-1/A2:1995	Safety requirements for electrical equipment for measurement control and laboratory use.
U.S. Nationally Recognized Testing Laboratory Listing	UL3111-1	Standard for electrical measuring and test equipment.
	ANSI/ISA S82.01:1994	Safety standard for electrical and electronic test, measuring, controlling, and related equipment.
Canadian Certification	CAN/CSA C22.2 No. 1010.1	Safety requirements for electrical equipment for measurement, control, and laboratory use.
Additional Compliance	IEC61010-1/A2:1995	Safety requirements for electrical equipment for measurement, control, and laboratory use.
Equipment Type	Test and measuring	
Safety Class	Class 1 (as defined in IEC 61010-1, Annex H) - grounded product	

6.4 Addresses

Thorlabs GmbH

Gauss-Strasse 11
D-85757 Karlsfeld
Fed. Rep. of Germany

Tel.: ++49 (0)81 31 / 5956-0
Fax: ++49 (0)81 31 / 5956 99

Email: profile@thorlabs.com
Internet: <http://www.thorlabs.com>
Technical Hotline: blueline@thorlabs.com

Our company is also represented by several distributors and sales offices throughout the world.

Please call our hotline, send an E-mail to ask for your nearest distributor or just visit our homepage <http://www.thorlabs.com>

A		L	
A/D	31	laserdiode	20
accessories.....	13	ld output.....	19
acronyms	39	letterplate	16
addresses	42	limit (current).....	14
C		line voltage.....	32, 37
calibration	29	M	
cc.....	25	mains voltage.....	16
certifications.....	40	modulation	29
cleaning	34	O	
compliances.....	40	operating elements	14
connector.....	18	P	
constant		photodiode	20
current.....	15, 25	polarity	20, 23
power	15, 26	R	
cp.....	26	remote control.....	31
current limit.....	14, 23	repair	34
D		S	
D/A	31	safety	1
display	14	service	37
F		T	
fuse.....	32, 38	technical data.....	6
G		troubleshooting	35
ground	16	W	
I		warranty.....	3
interlock	19, 35		