

SECTION A-A  
SCALE 1.5 : 1

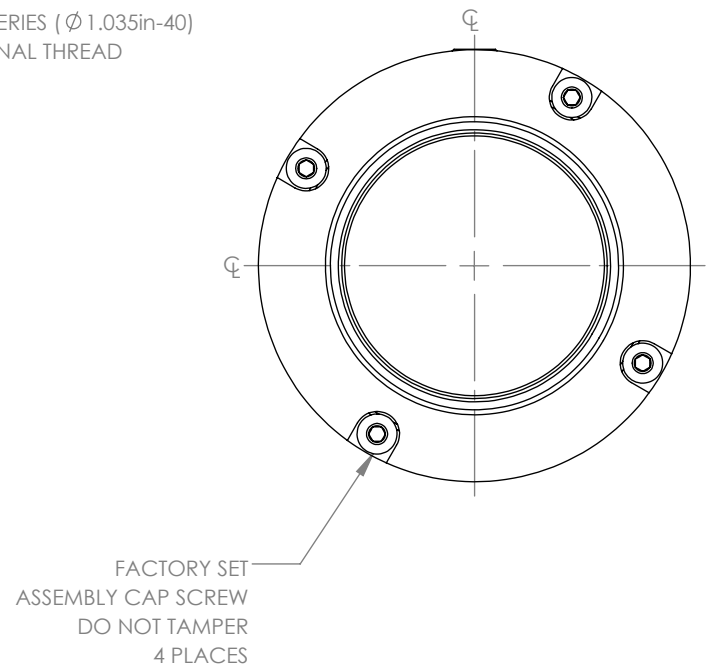

FOR INFORMATION ONLY  
NOT FOR MANUFACTURING PURPOSES

DRAWING PROJECTION			<b>THORLABS</b> www.thorlabs.com	
NAME	DATE	SM1 THREADED LOCKABLE ROTATION MOUNT FOR Ø 1" OPTICS		
DRAWN	HP	15/AUG/18	MATERIAL	ALUMINUM
APPROVAL	JG	20/AUG/18	ITEM #	LRM1
COPYRIGHT © 2018 BY THORLABS				
VALUES IN PARENTHESIS ARE CALCULATED AND MAY CONTAIN ROUND OFF ERRORS				
			APPROX WEIGHT	0.046 kg
				REV A