



### Description

Thorlabs' M420L3 Mounted LED has a nominal wavelength of 420 nm, outputs more than 750 mW of power, and is mounted to the end of a Ø30.5 mm heat sink. This LED needs to be supplied with a constant current that must not exceed 1000 mA. The current source must be able to deliver this current at a forward voltage of 3.5 V.

### Specifications

Specification	Value
Color	Violet
Nominal Wavelength	420 nm
Bandwidth (FWHM)	15 nm
Viewing Angle (Full Angle)	125°
Emitter Size	1 mm x 1 mm
Test Current for Typical LED Power	1000 mA
Maximum Current (CW)	1000 mA
Electrical Power	3500 mW
Typical Lifetime	>10 000 h
Operating Temperature (Non-Condensing)	0 to 40 °C
Storage Temperature	-40 to 70 °C
Risk Group <sup>a</sup>	RG2 - Moderate Risk Group

a. According to the standard IEC 62471:2006, Photobiological Safety of Lamps and Lamp Systems

M420L3				
	Symbol	Min	Typical	Max
Peak Wavelength	$\lambda_p$	-	419.8 nm	-
LED Output Power <sup>a</sup>	$P_{out}$	750 mW	820 mW	-
Forward Voltage	$V_F$	-	3.5 V	-
Maximum Irradiance <sup>b</sup>	$E_e$	-	13.1 $\mu\text{W}/\text{mm}^2$	-

a. When Driven with the Test Current

b. Measured at a Distance of 200 mm

### Operating Instructions

Be sure to provide air ventilation in order to avoid overheating, drops in optical power, and reduced lifetime. Each LED has a characteristic switch-on behavior, which depends on the LED properties and environment conditions. An important criterion is the heat dissipation. The M420L3 has a unique thermal design that reduces the power decay to a minimum.

The image to the bottom right shows the M420L3's male connector, which is a standard M8x1 sensor circular connector. Pins 1 and 2 connect to the LED. Pins 3 and 4 are used for the internal EEPROM. Only use these connections when using a Thorlabs LED driver.

After an LED is switched on, it will warm up which can cause decay in optical power. The heat sink of the M420L3 provides good thermal management, reducing the loss of power as the LED reaches its equilibrium temperature.

## Performance Plots

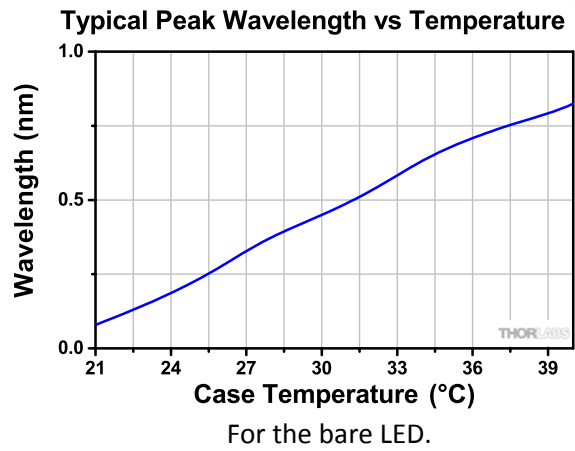
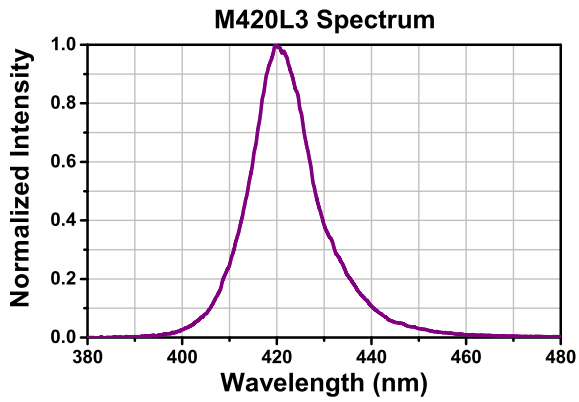

## Typical Spatial Radiation Distribution

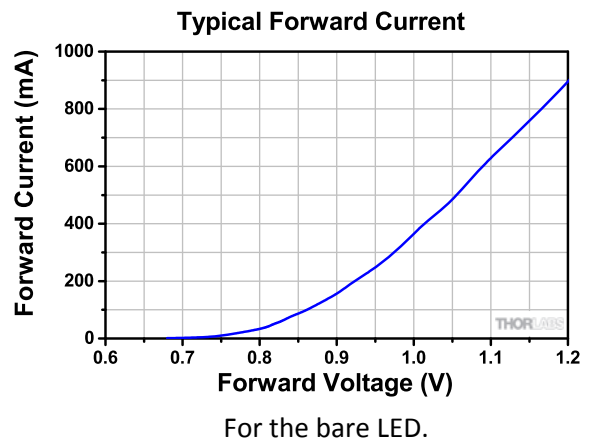
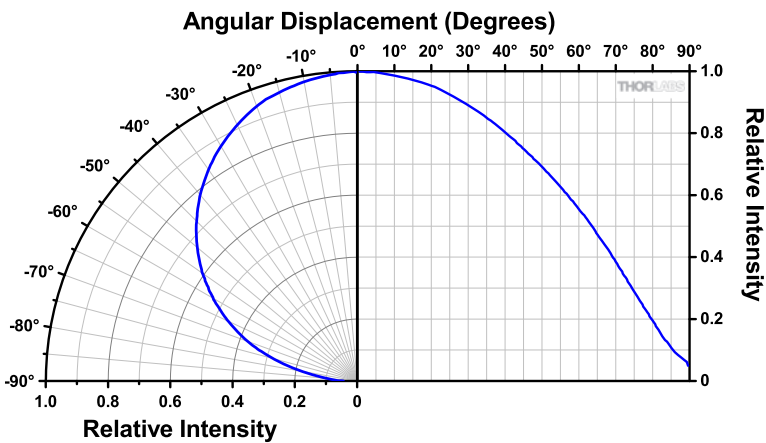

## Drawings

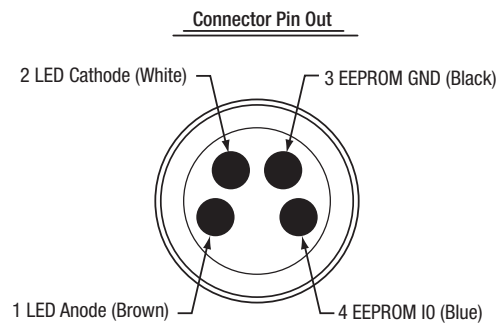
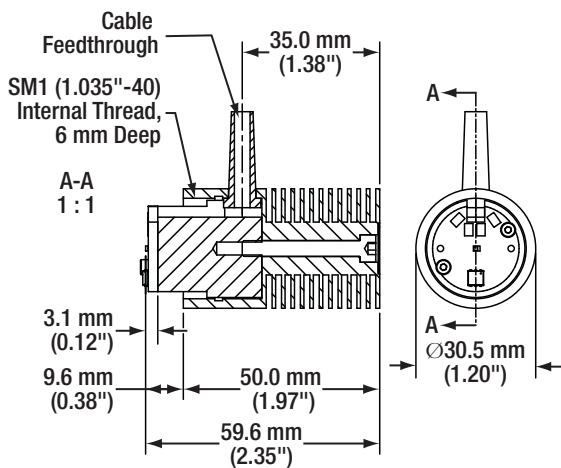

## Power Supply

We recommend using Thorlabs' DC2200 or LEDD1B LED current drivers (for control of a single LED). Alternatively, the DC4100 or DC4104 current driver can be used with the DC4100-HUB, which allows simultaneous control of up to 4 individual LEDs.

If you decide to use your own DC source, please make sure that the operating current does not exceed the maximum allowed value, sufficient forward voltage is supplied, and that the correct connection is made to Pins 1 and 2.

## Maintenance and Service

The M420L3 is not water resistant and must be protected from adverse weather conditions. To avoid damage, do not expose it to spray, liquids, or solvents. The M420L3 does not contain any parts serviceable by the user and does not require regular user maintenance. Do not open the enclosure. If a malfunction occurs, contact Thorlabs for return instructions.

## Warnings and Safety

Inappropriate use of any Mounted LED product may result in permanent eye damage. To prevent injury, use this product in accordance with the International Standard "Photobiological Safety of Lamps & Lamp Systems" IEC 62471. This LED falls under the Risk Group RG2 - Moderate Risk Group in accordance to the standard IEC 62471:2006.

If using this LED in a microscope application as a replacement for mercury vapor lamp, the same precautions should be taken.

During normal operation, the casing temperature may exceed ambient temperature by as much as 25 °C (45 °F). To prevent higher case temperatures, the products should be operated without anything hindering air movement around the convective cooling fins.

Please note that this product is not suitable for household room illumination.

This LED must not be operated in explosive environments and should only be used with shielded connection cables.

All statements regarding safety of operation and technical data only apply when the unit is operated correctly according to its specifications. The safety of any system incorporating the equipment is the responsibility of the assembler of the system.

### UV Warning Statement

This LED emits intense UV radiation during operation. Precautions must be taken to prevent looking directly at the UV light. If viewing the UV light is necessary, UV light protective glasses must be worn to avoid eye damage. Do not look directly into the UV light or look through the optical system during operation, as this can be harmful to the eyes, even for brief periods, due to the high intensity of the UV light.

