

Ø 13.0mm [Ø 0.51in] KNURLED GRIP
MICROMETER HEAD (148-801ST)
Ø 9.5mm [Ø 0.37in] BARREL
12.7mm [0.50in] TRAVEL
0.64mm [0.025in] PER-REV

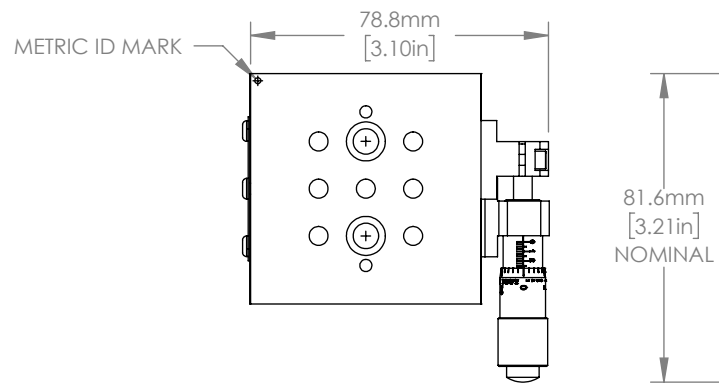

MT1/M SHOWN WITH OPTIONAL MT405
SIDE-MOUNTED ACTUATOR KIT

FOR INFORMATION ONLY
NOT FOR MANUFACTURING PURPOSES

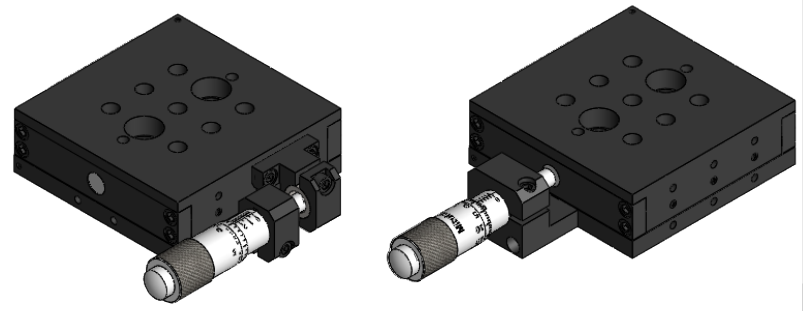

DRAWING PROJECTION			THORLABS www.thorlabs.com	
NAME	DATE	13mm TRANSLATION STAGE		
REDRAWN TLB	28/MAR/12	MATERIAL		REV F
APPROVAL SB	10/NOV/99	N/A		
COPYRIGHT © 2013 BY THORLABS				
VALUES IN PARENTHESIS ARE CALCULATED AND MAY CONTAIN ROUND OFF ERRORS		ITEM #	APPROX WEIGHT	
		MT1/M	0.20 kg	