



MX10B Series

12.5 Gb/s Optical Transmitters

MX40B Series

40 Gb/s Optical Transmitters

User Guide

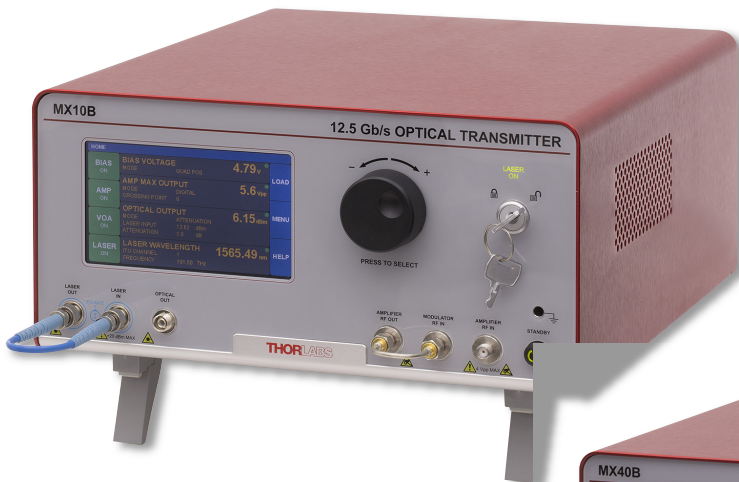

Table of Contents

Chapter 1 Introduction	1
1.1 Description	1
1.2 Parts List	1
1.3 Block Diagram	2
1.4 Front and Back Panel Overview	3
Chapter 2 Safety	5
2.1 Precautions	6
Chapter 3 Quick Start Guide	7
3.1 Hardware Set Up	7
3.2 Controls on the Home Page	8
3.3 System Wavelength Setting	9
3.4 Controls on the Settings Pages	10
3.5 Quick Start	11
Chapter 4 Operating Instructions	12
4.1 The Modulator Transmission Function	12
4.2 Control Loop Diagram	12
4.3 Bias Settings Page	13
4.3.1 Quadrature Mode	14
4.3.2 Peak Mode	16
4.3.3 Null Mode	16
4.3.4 Manual Mode	17
4.4 Amplifier Settings Page	19
4.5 Variable Optical Attenuator Settings Page	21
4.6 Laser Settings Page	22
4.7 Load Page	24
4.8 Menu Page	25
4.8.1 Display and Sound Settings Page.....	25
4.8.2 System Information Page	26
4.8.3 Accent LED Settings Page.....	26
4.8.4 Thorlabs Help Page	27
Chapter 5 Specifications	28
5.1 General System Specifications	28
5.2 Power and Environmental Specifications	29
5.3 Internal Control Specifications	29
5.4 Internal Amplifier Specifications	30
5.5 Laser Specifications	31
Chapter 6 Control and PC Connections	32
6.1 General Purpose I/O, RS-232, and USB Connections	32
6.2 The Laser Safety Interlock	33
Chapter 7 Mechanical Drawings	34
7.1 MX10B Series	34

7.2	MX40B Series	35
Chapter 8	Maintenance, Repair, and Fuses	36
8.1	Maintenance and Repair	36
8.2	Replacement Parts	36
8.3	Replacing the Main Fuse.....	37
Chapter 9	Troubleshooting	38
Chapter 10	Declarations of Conformity.....	39
Chapter 11	Thorlabs Worldwide Contacts	41

Chapter 1 Introduction

1.1 Description

Thorlabs' MX10B and MX40B series of reference transmitters are designed for high-speed fiber optic test and measurement applications. They are fully-integrated and user-configurable solutions based on proven lithium niobate (LiNbO₃) modulator technology driven by high-fidelity digital RF amplifiers. They are designed for digital applications, and the maximum output swing of their limiting RF amplifiers is user-adjustable. Variable optical attenuators (VOAs) and power monitors enable completely automatic control and stabilization of the optical output power. Transmitters in the MX10B series include an external loop-back cable for the driver RF output and modulator RF input ports, which provides the opportunity to use an external driver, if desired.

The MX10B/MX40B, MX10B-LB/MX40B-LB, and MX10B-1310/MX40B-1310 include a tunable C-band laser, a tunable L-band laser, and a 1310 nm fixed-wavelength laser, respectively. Both the C- and L-band laser sources are tunable on the ITU 50 GHz grid and include a dither feature for wavelength stabilization. An external laser source, operating from 1250 nm to 1610 nm, can also be used with all models to provide the optical input.

These instruments can be controlled in two ways. The simplest method is directly via the built-in graphical user interface (GUI) and touchscreen. The instrument can also be operated remotely via the RS-232 or USB ports on the back panel. Remote control is enabled using simple SCPI-type serial commands from a PC. See the remote control user guide (RCUG), which can be downloaded from <https://www.thorlabs.com/manuals.cfm>, for details.

The most recent firmware and remote control software tools can be downloaded by visiting https://www.thorlabs.com/navigation.cfm?Guide_ID=2191 and entering the Item # into the search field. Thorlabs' technical support can provide up-to-date information on available firmware revisions and control functions.

NOTE: This manual covers both the MX10B and MX40B series of models, as their architectures are very similar. Their differences are clearly noted in the following sections.

1.2 Parts List

Inspect the shipping container for damage. If the shipping container seems to be damaged, keep it until you have inspected the contents and tested the unit mechanically and electrically. Verify that you have received the following items within the package:

1. MX10B or MX40B Series Optical Transmitter Main Unit
2. Power Cord According to Local Power Supply
3. PM Loopback Fiber Optic Cable
4. SMA Loopback RF Cable (not required for MX40B series)
5. Interlock Keys
6. 2.5 mm Interlock Pin (in back panel)
7. 1.25 A 250 VAC Fuse
8. USB Type A to Type B Cable, 6' Long

1.3 Block Diagram

These instruments are fully integrated and contain both the laser source and the intensity modulator. The modulator is a Mach-Zehnder configuration and will often be referred to as the MZM. All the user needs to supply is the signal source to the Amplifier RF In port. The user can choose to use the internal laser source (via loop-back fiber) or an external laser source of their own. The Laser In port uses PM fiber with light linearly polarized along the slow axis as shown on the front panel. Maximum input power is 20 dBm (100 mW). In the MX10B series of transmitters, the user also has the option of using their own modulator driver connected to the Modulator RF In port. The MX40B series does not have this option in order to preserve signal integrity. Optical power is monitored in three places (Mon-1,-2,-3) for the purpose of enabling bias and power control. These power values are also available at the I/O port. Mon-1 is at the Laser Input, Mon-2 is at the MZM Output, and Mon-3 is at the final Optical Output.

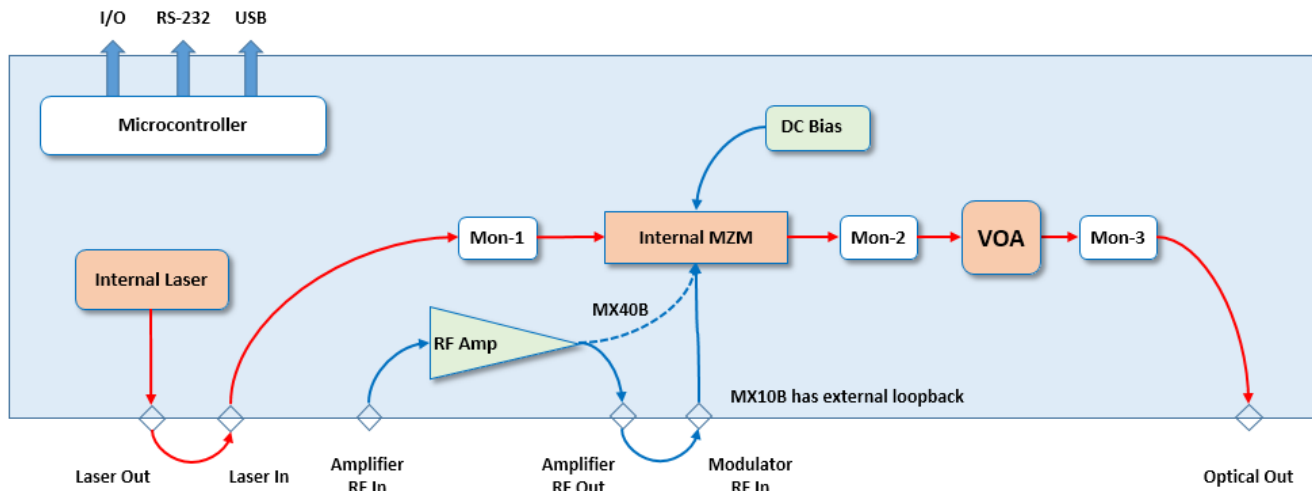

Figure 1 Block Diagram of the MX10B and MX40B Series

1.4 Front and Back Panel Overview

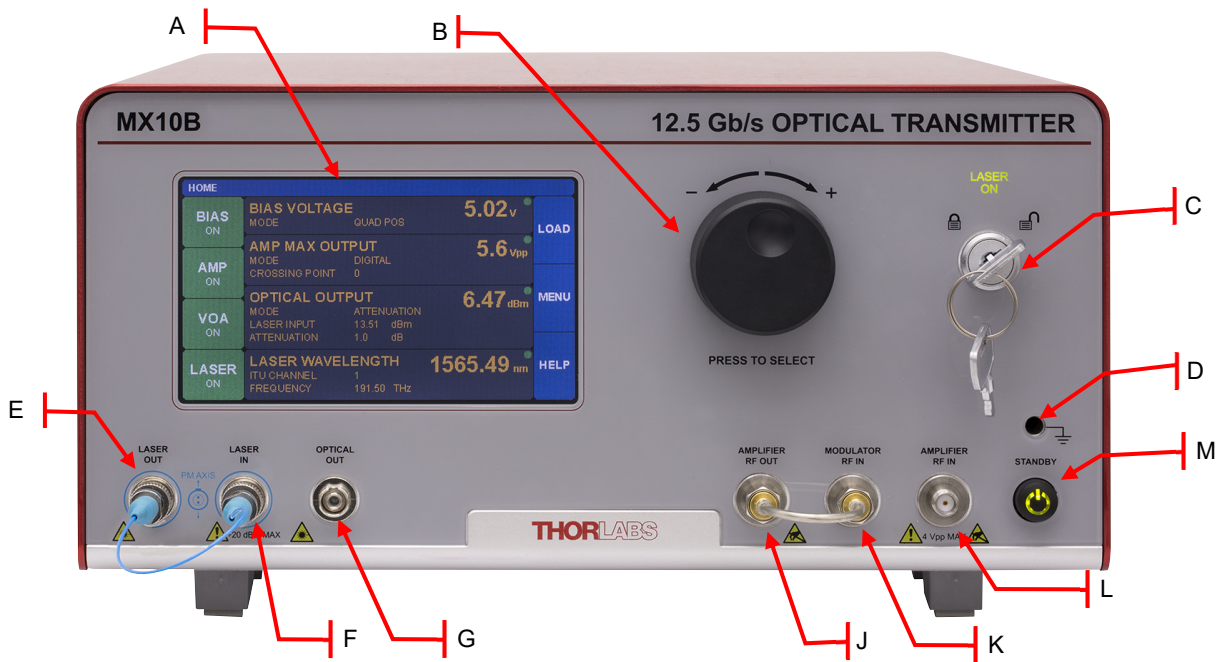

Figure 2 Front Panel

Callout	Description	MX10B Series	MX40B Series
A	Touchscreen Display	-	-
B	Adjustment Knob	-	-
C	Key Switch and Indicator ☰ Lasing Disabled; ☑ Lasing Enabled	-	-
D	Grounding Jack (Banana Connector) ⚡ Earth Ground	Banana	Banana
E	Laser Output	PM FC/PC	PM FC/PC
F	Laser Input	PM FC/PC	PM FC/PC
G	Optical Output	FC/PC	FC/PC
J	Amplifier RF Output	SMA	Not Available
K	Modulator RF Input	SMA	Not Available
L	Amplifier RF Input	SMA	2.92 mm
M	Standby Button	-	-

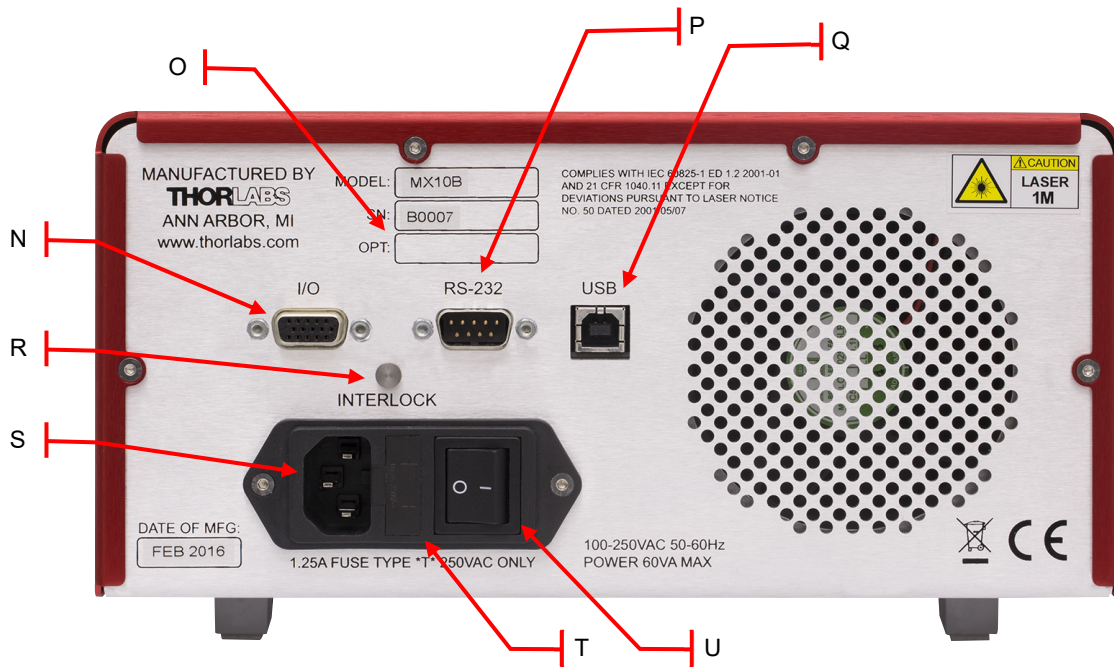

Figure 3 Back Panel

Callout	Description	MX10B Series	MX40B Series
N	I/O Port	DB-15	DB-15
O	Option Label	-	-
P	RS-232 Port	DB-9	DB-9
Q	USB Port, Type B	-	-
R	Laser Interlock	2.5 mm	2.5 mm
S	Power Connector	-	-
T	Fuse Tray	-	-
U	Power Switch I Supply On; O Supply Off	-	-

Chapter 2 Safety

All statements regarding safety of operation and technical data in this instruction manual will only apply when the unit is operated correctly. If equipment is used in a manner not specified by the manufacturer, the protection provided by the equipment may be impaired. Only with written consent from Thorlabs may changes to single components be carried out or components not supplied by Thorlabs be used.

**Warning: Risk of Electrical Shock**

Before applying power to the instrument, make sure that the protective conductor of the 3 conductor mains power cord is correctly connected to the protective earth contact of the socket outlet. Improper grounding can cause electric shock with damage to your health or even death. The local supply voltage must be in the range specified on the back panel, and the correct fuse must be installed in the fuse holder. If not, please replace the main fuse (see section on instrument maintenance). Only use mains cable with sufficient current and voltage ratings for this instrument. Do not position equipment in a way that makes it difficult for the user to operate the disconnecting device. Do not remove covers. Refer servicing to qualified personnel.

**Warning: Risk of Explosion**

The instrument must not be operated in explosion endangered environments.

**Warning: Laser Radiation**

Avoid Exposure – Radiation emitted from apertures. Do not look into the laser aperture while the laser is on. Injury to the eye may result. Laser should not be turned on unless there is an optical fiber connected to the laser output port.

Caution – Use of controls or adjustments or performance of procedures other than those specified herein may result in hazardous radiation exposure.

**Caution: ESD Sensitive Component**

The components inside this instrument are ESD sensitive. Take all appropriate precautions to discharge personnel and equipment before making any connections to the unit. A front panel grounding jack is provided for connection to a wrist strap.

**Caution: Components not Water Resistant**

This instrument should be kept clear of environments where liquid spills or condensing moisture are likely. It is not water resistant. To avoid damage to the instrument, do not expose it to spray, liquids, or solvents.

**Caution: Follow Intended Usage Guidelines**

This product is not suitable for household room illumination.

Inputs and outputs must only be connected with shielded connection cables.

Do not obstruct the air ventilation slots in housing.

Mobile telephones, cellular phones or other radio transmitters are not to be used within the range of three meters of this unit since the electromagnetic field intensity may then exceed the maximum allowed disturbance values according to IEC 61326-1.

2.1 Precautions

The following statement applies to the products covered in this manual, unless otherwise specified herein. The statement for other products will appear in the accompanying documentation.

Note: This equipment has been tested and found to comply with the limits for a Class B digital device, pursuant to Part 15 of the FCC Rules and meets all requirements of the Canadian Interference Causing Equipment Standard ICES-003 for digital apparatus. These limits are designed to provide reasonable protection against harmful interference in a residential installation. This equipment generates, uses, and can radiate radio frequency energy and, if not installed and used in accordance with the instructions, may cause harmful interference to radio communications. However, there is no guarantee that interference will not occur in a particular installation.

This product has been tested and found to comply with the limits according to IEC 61326-1 for using connection cables shorter than 3 meters (9.8 feet).

Thorlabs is not responsible for any radio television interference caused by modifications of this equipment or the substitution or attachment of connecting cables and equipment other than those specified by Thorlabs. The correction of interference caused by such unauthorized modification, substitution or attachment will be the responsibility of the user. The use of shielded I/O cables is required when connecting this equipment to any and all optional peripheral or host devices. Failure to do so may violate FCC and ICES rules.

This precision device should only be shipped if packed into the complete original packaging including the custom cut foam padding. If necessary, ask for replacement packing material.

Chapter 3 Quick Start Guide

3.1 Hardware Set Up



For first use, plug the main power cable into the back panel connector, and then plug the other end into an AC wall receptacle. Flip the power switch on the back panel to the ON (I) position. The unit will now be in the “Standby” mode, and the front panel standby button should glow amber.



Figure 4 Power Cable Port, Fuse, and Power Switch



Figure 5 Indicator Glows Amber when Instrument is In Standby

Attach the polarization-maintaining (PM) loopback fiber optic cable between the Laser Out and Laser In PC/FC connectors on the front panel. Be sure to clean both ends of the fiber as described in the Maintenance Section of this manual. For the MX10B series: attach the SMA loopback RF cable between the Amplifier RF Out and Modulator RF In SMA connectors on the front panel. (This instruction does not apply to the MX40B series, as it does not have an Amplifier RF Out port.)



Figure 6 PM Loopback Fiber Cable Installed



Figure 7 Amplifier RF Out present only on the MX10B series of transmitters. This cable is not installed on the MX40B transmitter series.

Insert the key into the interlock switch and turn it towards the unlock symbol (🔓). This allows the laser to be turned on, but the LASER ON indicator will not glow green until the laser is actually turned on by the touchscreen button. Turn on the unit by pressing the amber standby button on the front panel which will then turn green to indicate the unit is fully on. The touchscreen display will come up with a boot screen for about 5 seconds and then go to the home page. The unit will initialize in the factory default state with all functions OFF.



Figure 8 Interlock Key Switch



Figure 9 Indicator Glows Green when Instrument is Fully Enabled

3.2 Controls on the Home Page

The MX10B and MX40B series of transmitters can be fully controlled by using the resistive touchscreen display for all functions. The screen is sensitive to the touch of a finger or a plastic stylus, and selections are made by tapping the on-screen button of interest. In addition, the knob on the front panel can be used in place of the on-screen arrow buttons for quickly changing set-point values. Pressing (clicking) the knob will confirm a new set-point value.

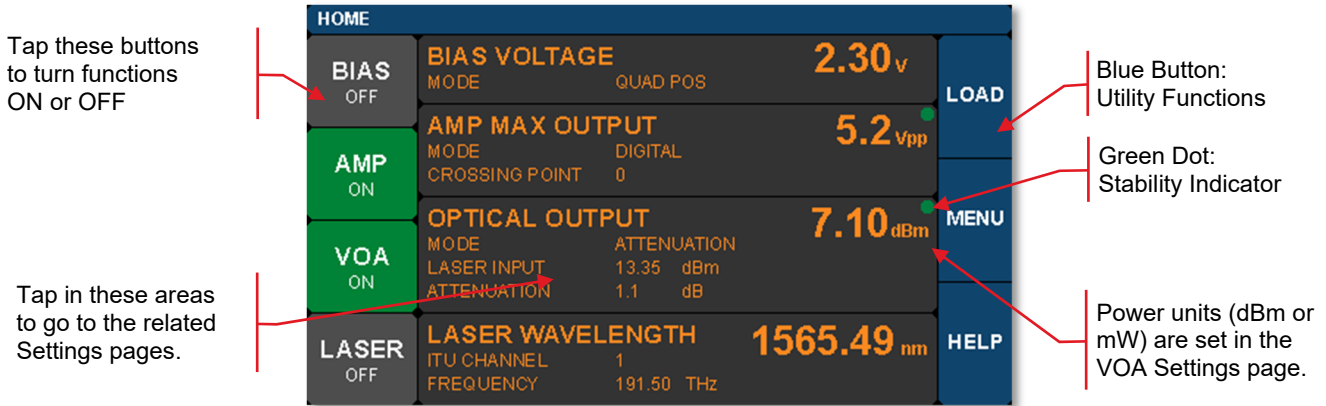

Figure 10 Home Screen Features

The Home screen (or dashboard) is organized into three main sections.

The left side contains the ON/OFF buttons for each of the main instrument functions. Tapping any of these buttons will toggle the function on and off. The same ON/OFF functionality is also available on the individual Settings pages. The power buttons turn green to indicate the function is ON, and turn red to indicate the function is disabled.

The central section is the main dashboard for reporting operational values of each section. Tapping the screen in this middle area will take the user to the corresponding Settings page for each section. Note that the green dot in each of these sections indicates the function is stable. A blinking green dot indicates the function is still stabilizing.

The right side of the screen provides access to the main utility functions of the box.

The screen shot below shows some of the common warning indicators on the HOME page. Some functions can be disabled when the laser power is low. In this case, buttons may be disabled and warnings indicators may appear.

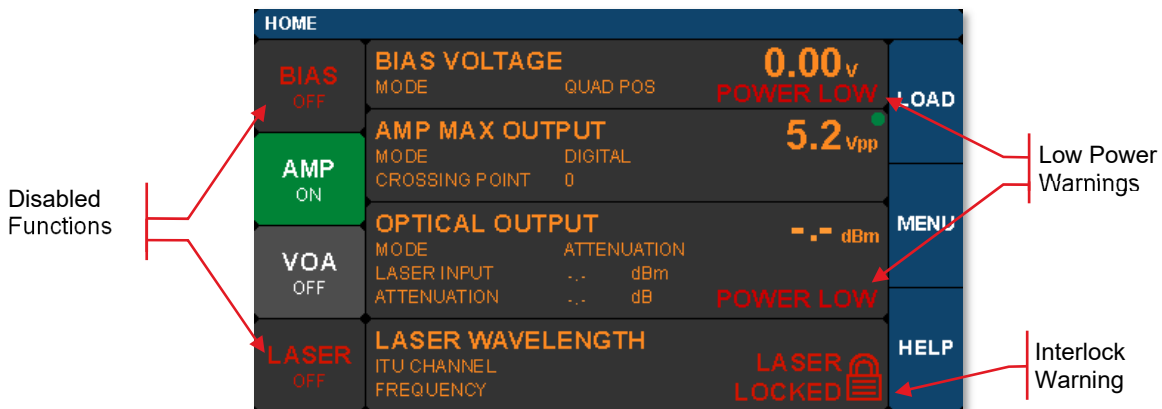

Figure 11 Home Screen Warnings and Indicators

3.3 System Wavelength Setting

The operational wavelength range of the MX10B and MX40B series extends from 1250 nm to 1610 nm. The three calibration wavelengths of the power monitors, 1310 nm, 1550 nm, and 1590 nm, represent the centers of the O-band, C-band, and L-band and provide the user with accurate power readings at or near those wavelengths.

The system wavelength should always be set to the wavelength closest to that of the laser source coupled to the Laser In bulkhead. The instrument's system wavelength is factory-preset to correspond to the wavelength band of the integrated laser source. If an external laser is to be used with the instrument, the system wavelength may need to be changed. This function exists in the Utility Menu.

From the Home screen, tap the MENU button to bring up the Utility Menu as shown.

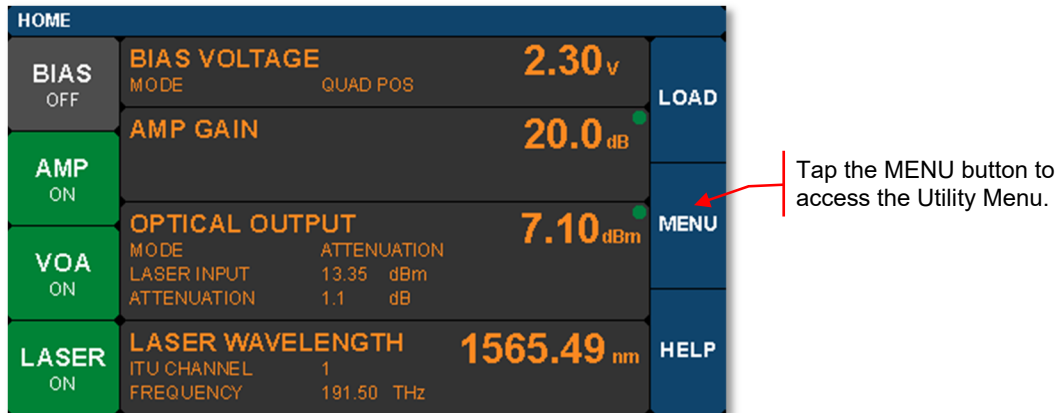

Figure 12 Accessing the Utility Menu from the Home Screen

Then tap the System Wavelength bar as shown below to bring up the three wavelength choices. Tap the desired wavelength to set the System Wavelength.

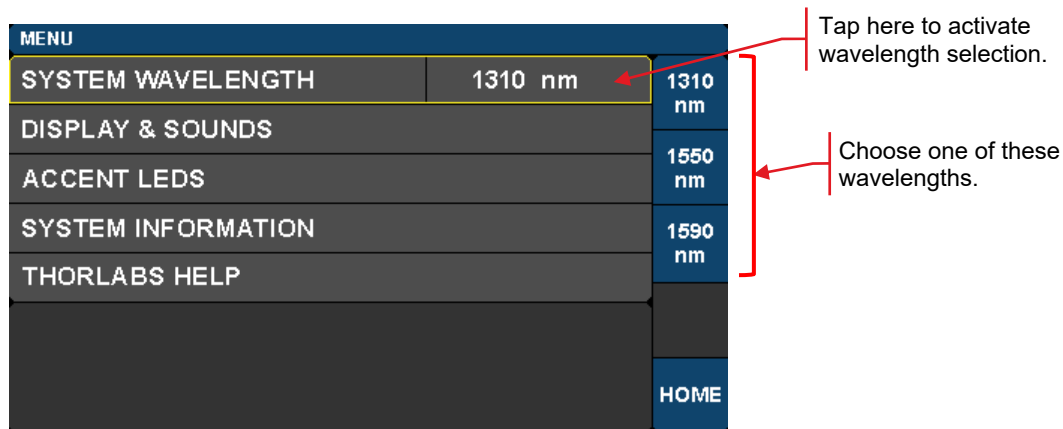

Figure 13 System Wavelength is Selected from the Utility Menu

3.4 Controls on the Settings Pages

The Settings pages all follow the same general design and functionality as shown in the example screen shot below. The upper section with white letters displays the parameters that can be changed. Simply tap on the parameter of interest to highlight it, and the controls for that parameter will be presented.

The lower section with amber letters displays selected values that are convenient to monitor on that page.

The right-hand column provides the controls for changing the values for the selected parameters. The main control knob on the front panel can also be used to adjust and confirm selected values. The screen shots below show examples of the touch-screen controls.

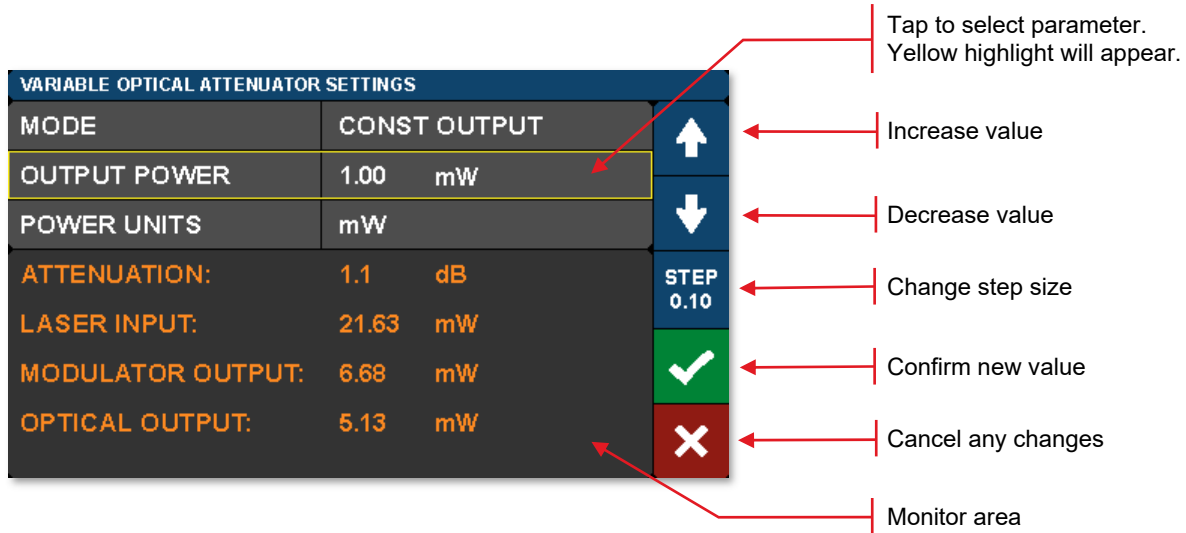

Figure 14 Controls used to Adjust and Save Values of Selected Parameters

Fields that have adjustable values will show a flag if the minimum or maximum values have been reached. These are set by firmware at the factory.

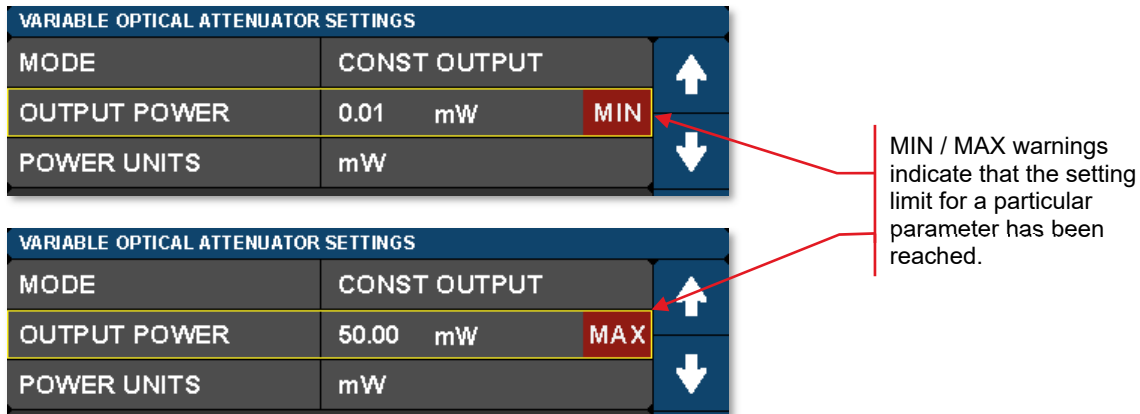

Figure 15 MIN and MAX Flags Indicate Bounds of Adjustable Value Ranges

3.5 Quick Start

The following steps summarize the setup procedure required to operate the MX10B and MX40B series in the standard mode. Please refer to previous sections in this chapter and the expanded operating instructions in Chapter 4 for additional information.

1. Turn on power to the MX10B or MX40B series transmitter via the power switch on the back panel (Figure 4).
2. Press and hold the button on the front panel until the indicator light changes from amber to green (Figure 5 and Figure 8).
3. Turn the key switch to unlock (Figure 8).
4. Turn the laser on by tapping the lower-left touchscreen button on the Home page (Figure 10). Use the utility menu page to adjust the calibration wavelength if desired (Section 3.3).
5. Enable the bias controller by tapping the top-left touchscreen button on the Home page (Figure 10). Wait for completion of the calibration process. The instrument will enable the default Quadrature mode with positive slope bias point (Section 4.3).
6. Take note of the output power, which is shown in the center right section of the Home page (Figure 10).
7. Turn on the VOA controller to adjust output power, if desired, by tapping the center-left touchscreen button on the Home page (Figure 10 and Section 4.5).
8. Turn on the AMP controller to set desired swing level (Figure 10 and Section 4.4).
9. Apply the input RF signal to the female SMA connector(s) on the front panel (Figure 5), noting the specified limits for limiting response (5.4). If an input is unused, it must be terminated with one of the included 50-Ohm loads.
10. For additional information on a lower-noise operating mode, see information about Ratio Mode in Section 4.3.4.

Chapter 4 Operating Instructions

4.1 The Modulator Transmission Function

The Mach-Zehnder Modulator (MZM) has a repetitive transmission function with applied voltage as can be seen in the diagram below. In order for it to work correctly, a DC bias voltage must be applied and maintained at the desired set point. The high-frequency AC signal can then be applied to the modulator to enable the correct optical modulation of the laser beam. The most common operating points are the peak, null, and quadrature points as shown below.

The purpose of the Bias settings is to hold the modulator at one of these chosen points. Note that a real transmission function does not go perfectly from 0% to 100%. This is characterized by the Extinction Ratio of the modulator (Peak power / Null power). The efficiency of the modulator is also characterized by V_{π} , which is defined as the voltage necessary to change the transmission from Null to Peak. The most linear response of the modulator is achieved by biasing it at one of the Quadrature points where the transmission is closest to 50%. Some non-linear, frequency doubling, and phase modulation applications require biasing at the Null or Peak.

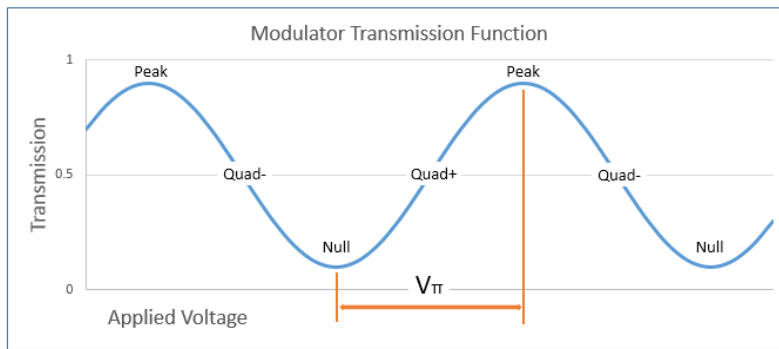

Figure 16 Illustration of the Modulator Transmission Function

4.2 Control Loop Diagram

The following diagram shows the control loops added to the block diagram. From this picture, the user can see how the power monitors and VOA are used to provide stability and control to the whole system. It will be helpful to refer to this diagram to gain a better understanding of the functionality of the unit as described in the upcoming sections of the manual. Note the MX40B series does not have the external RF loopback.

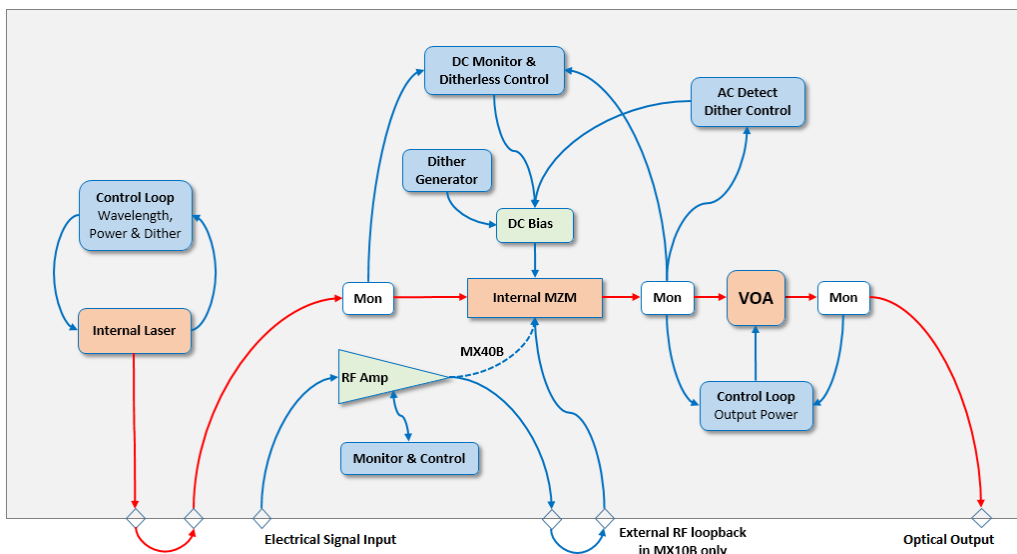

Figure 17 Control Loops Overlaid on Block Diagram

4.3 Bias Settings Page

To get to the Bias Settings page tap the Bias monitors pane on the Home page. The Bias page contains the settings for controlling the modulator bias and operating modes. There are four modes for MZM bias control: 1) Quadrature, 2) Peak, 3) Null, and 4) Manual. The screen shot below is an example of how the bias settings page opens up if the controller is in the Quadrature mode. The blue buttons enable switching between modes.

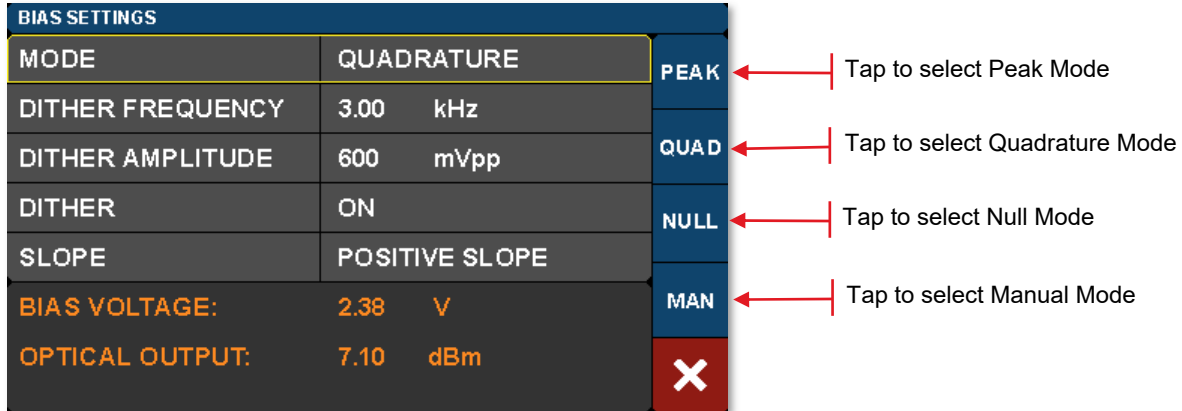

Figure 18 Bias Settings Page

Active control of the MZM bias point is essential as the modulator is temperature sensitive and will drift over time. The Quadrature, Peak, and Null modes use a dither tone as part of a lock-in control scheme to keep the MZM bias stable. The dither tone allows the control algorithm to track the drifting, but at the cost of decreased signal-to-noise ratio (SNR) due to the injection of a single frequency tone into the MZM bias.

The first time you turn on the MZM Bias control, the instrument will perform a calibration routine to determine the approximate bias voltages required for the various MZM operating points. This allows the instrument to quickly and effectively switch between Bias modes. The user may perform this calibration anytime by pressing the Reset Auto Bias button on the right side of the Bias Settings page. This button is not available if the Bias is off or in Manual mode.

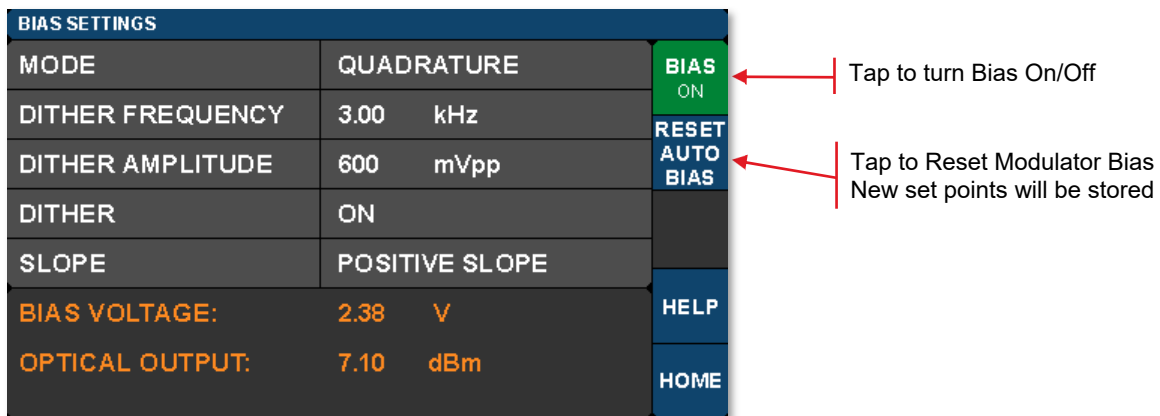

Figure 19 Buttons to Manually Initiate Modulator Calibration Routine

4.3.1 Quadrature Mode

Quadrature is the default mode and biases the MZM at the 50% point on the MZM transmission curve (see figure). This is the recommended mode for digital signals such as On-Off-Keying (OOK) that require a high extinction ratio. The screen-shot below shows the parameters that can be controlled in the Quadrature mode.

BIAS SETTINGS		
MODE	QUADRATURE	1 kHz
DITHER FREQUENCY	3.00 kHz	3 kHz
DITHER AMPLITUDE	600 mVpp	5 kHz
DITHER	ON	USER DEFINE
SLOPE	POSITIVE SLOPE	X
BIAS VOLTAGE:	2.38 V	
OPTICAL OUTPUT:	7.10 dBm	

Choose one of three preset Dither Frequencies.

Select your own Dither Frequency here.

Figure 20 Buttons to Select Preset and Define Custom Dither Frequencies

The bias control circuit uses an AC dither tone to stabilize the bias point of the modulator. The graphic below shows how it works:

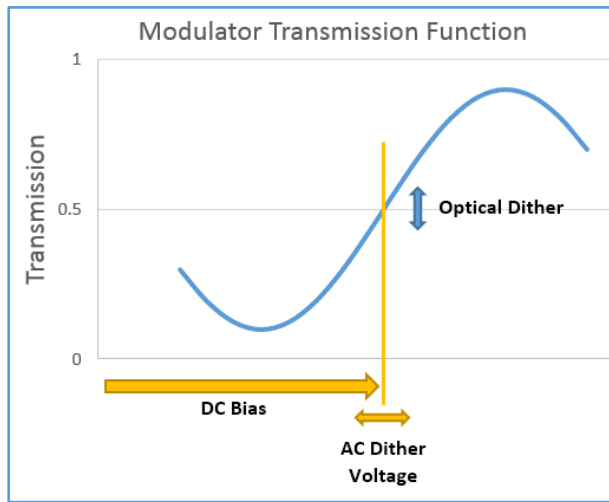

Figure 21 Illustration Showing How Dither is Used to Stabilize Modulator Bias Point

A small AC voltage is applied to the DC bias so that the optical output is also slightly modulated. Both the amplitude and the frequency of AC dither tone can be selected by the user. The modulated optical output is detected by a frequency and phase sensitive detector which can then interpret whether the DC bias is at the correct level for the chosen set-point (Quad, Peak or Null). The DC bias voltage is then continuously adjusted to maintain the correct set-point.

The frequency of the dither tone (under 10 kHz) is usually well below the low frequency cut-off for the RF signal of interest, so it does not interfere. The dither tone can also be turned if other methods of bias control are desired (e.g. manual control, or input/output ratio control as described later).

The dither tone frequency may be changed by tapping the Dither Frequency field. Standard frequencies are available on the blue buttons, or a custom frequency may be chosen by pressing User Define. The dither tone frequency usually has very little effect on the accuracy of the bias control, but in some cases a different frequency may work better or be desirable depending on the RF signal applied, or the specific application. The User Define button allows for the selection of an arbitrary frequency between 1 kHz and 10 kHz with 10 Hz resolution.

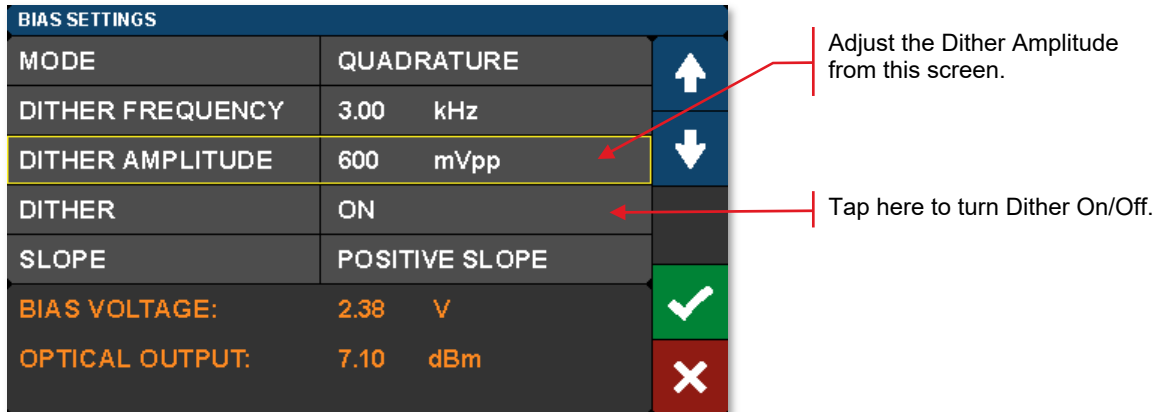

Figure 22 Adjust, Enable, or Disable the Dither Used to Stabilize the Bias Point

The dither tone amplitude can also be adjusted to any amplitude between 20 mV and 2 V with 1 mV resolution. Higher amplitude will typically be more stable in the presence of MZM drift and broadband RF signals, but larger dither tones also decrease SNR. If the amplitude is too low, the MZM bias may not stay locked. Typically, a value between 300 mV and 500 mV is a good starting point.

In applications where the highest SNR is desired, there is also the option to disable the dither tone. This allows the user to quickly turn the dither off, perform a measurement requiring low noise, and then turn the dither back on. When the dither is turned off, the bias is simply held at the previous bias voltage. For longer term measurements without dither, you can switch to Manual Mode and use a constant ratio method for stabilizing the bias point. (See the Manual Mode section.)

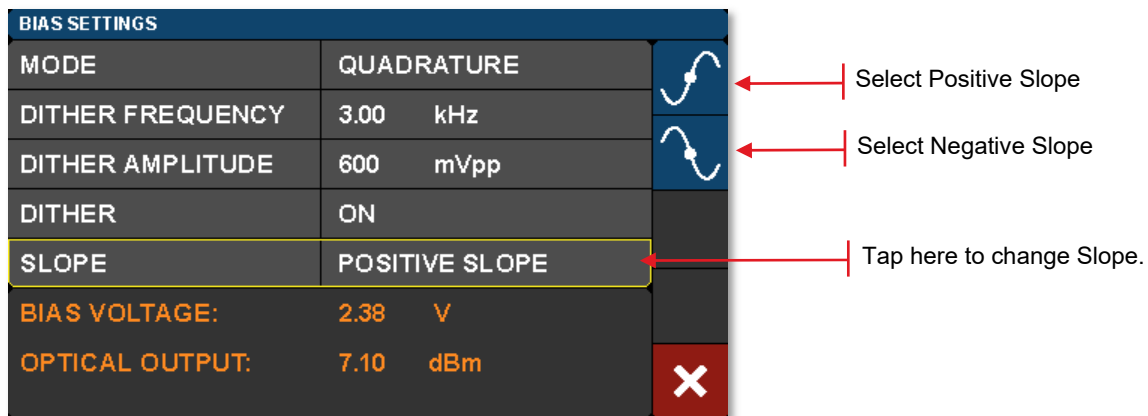

Figure 23 Locate Bias Point on Positive or Negative Slope

The Quadrature mode also allows the user to select between two operating points by selecting the Slope field. Positive slope is the non-inverting operating point where increasing voltage on the MZM results in increasing optical output power. Negative slope is the inverting operating point where increasing voltage on the MZM results in decreasing optical output power. This effectively changes the phase of the response function.

4.3.2 Peak Mode

The Peak Mode adjusts the DC bias voltage so the transmission is centered at a nearby transmission maximum. In this mode only dither frequency and amplitude settings are available. These controls and settings are the same as previously described for the Quadrature mode.

Peak and Null modes are often used to obtain phase modulation and non-linear frequency doubling. The optical phase is 180° shifted on opposite sides of the Null point.

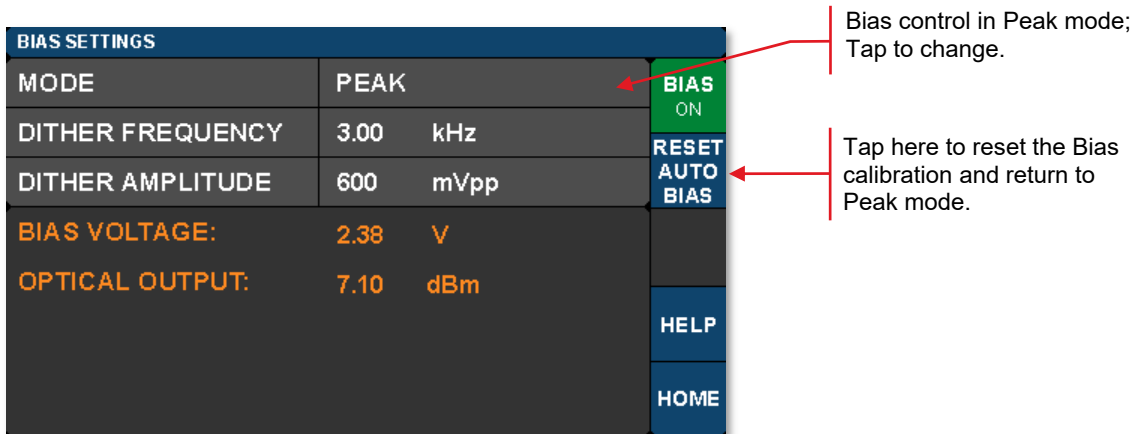

Figure 24 Peak Mode Settings

4.3.3 Null Mode

The Null Mode adjusts the DC bias voltage so the transmission is centered at a nearby transmission minimum. In the Null mode only dither frequency and amplitude settings are available. These settings are the same as previously described for the Quadrature mode.

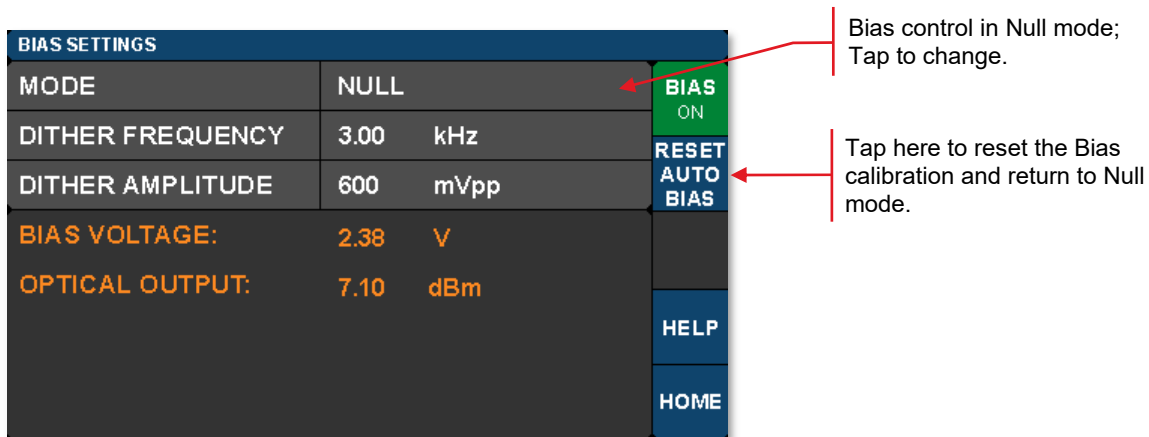

Figure 25 Null Mode Settings

4.3.4 Manual Mode

The Manual mode allows the user to bias the modulator at any point of the transmission function desired. Manual mode offers two modes of operation: 1) Constant Bias, and 2) Constant Ratio. In both of these modes, the dither function is not active, and the controller uses different techniques to hold the bias steady.

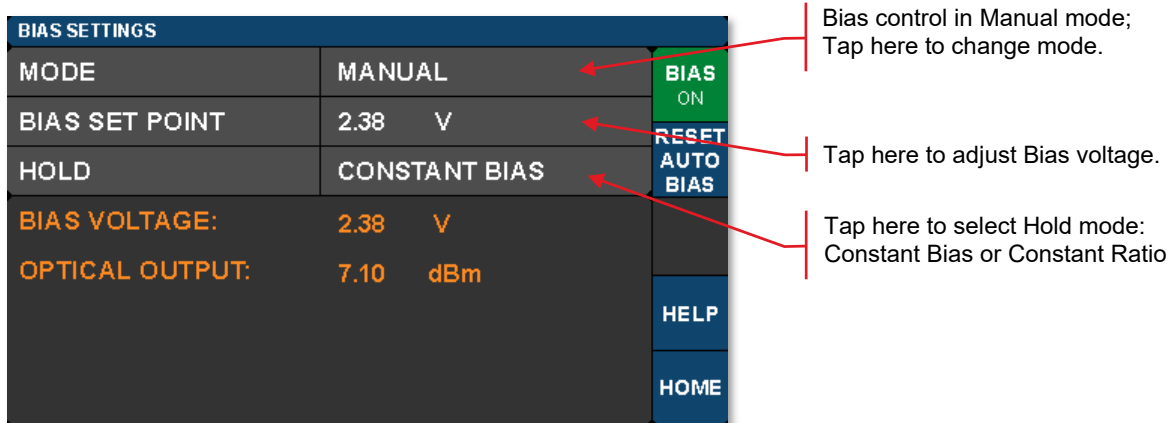

Figure 26 Constant Bias Manual Mode Settings

Constant Bias is the most basic mode of operation and will apply a user selected DC voltage to the MZM. This can be useful for performing brief measurements that only take a few minutes. During longer duration experiments, the MZM is more likely to drift.

The Constant Ratio mode employs active control of the MZM bias, but without using a dither tone. As a result, it can achieve superior SNR compared to the Quadrature mode. This mode is recommended for analog signals or higher level Pulse-Amplitude Modulation (PAM) formats.

Constant Ratio works by holding the MZM ratio of input light (at Mon-1) to output light (at Mon-2) at a constant value (typically at or close to Quadrature). Note that it does NOT take into account the insertion loss of the MZM. Therefore, the user must have some knowledge of the IL between the Monitors. For example. If the modulator has an IL of 3 dB, then the I/O ratio at maximum transmission is already 2:1. To bias the modulator at the 50% point, the ratio must be doubled to 4:1. The MZM insertion loss is listed in the specifications.

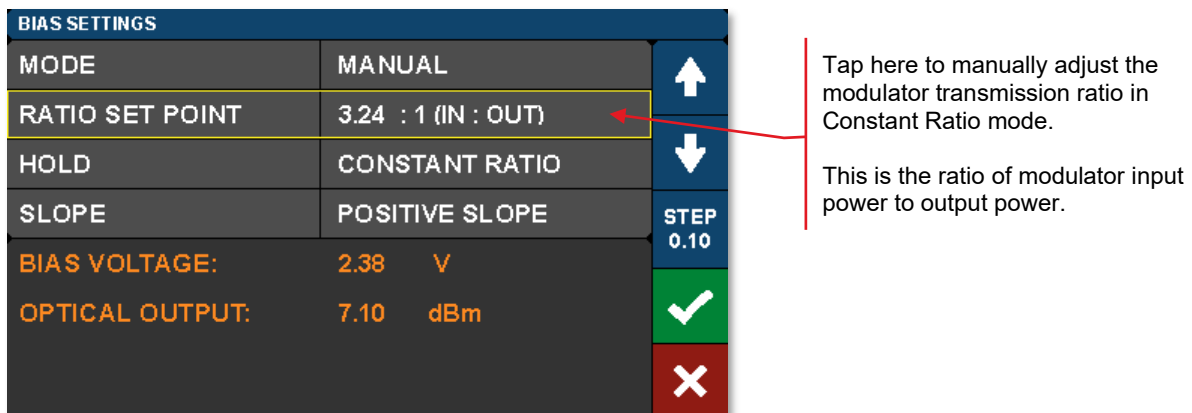

Figure 27 Constant Ratio Manual Modes Settings

In the Constant Ratio mode there is an option to select between the two available operating regions by selecting the Slope field. Positive slope is the non-inverting operating point where increasing voltage on the MZM results in increasing optical output power. Negative slope is the inverting operating point where increasing voltage on the MZM results in decreasing optical output power.

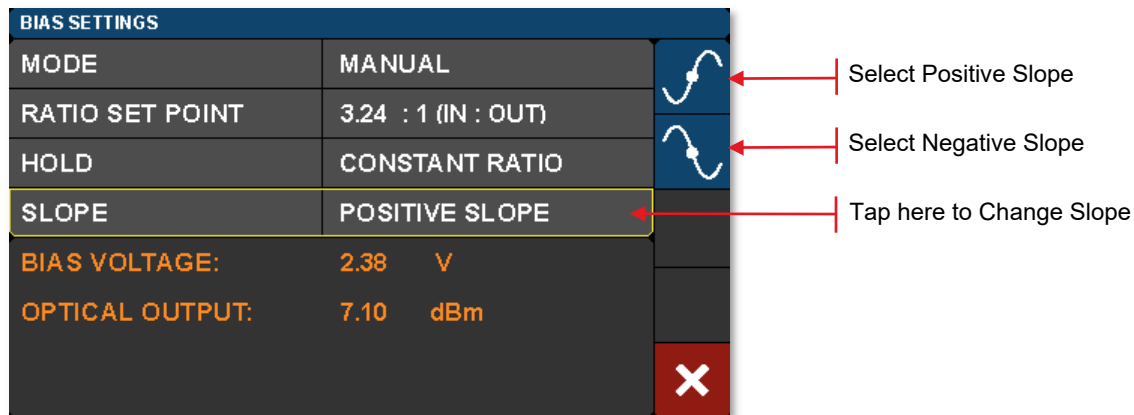

Figure 28 Selecting Operating Point in Constant Ratio Mode

When switching to one of the Manual modes from a different bias mode, the Manual mode set point is automatically calculated to keep the MZM at the same location on the transmission function. For example, in order to switch to Constant Ratio mode at the Quadrature location, follow these steps:

- Turn the bias on, and choose Quadrature mode.
- Wait for the green indicator dot to stop blinking (indicating the bias is locked at quadrature)
- Optional: For greater accuracy at this point, slowly reduce the dither tone amplitude to ~100 mV in order to remove errors that can occur due to second order effects with a large dither tone. Make sure the green dot is not blinking
- Now change the bias mode to Manual and select Constant Ratio.
- The instrument will calculate the ratio to keep the MZM biased at the Quadrature location.
- From here, the ratio set point can be adjusted to further tune performance.

4.4 Amplifier Settings Page

To get to the Amplifier Settings page, tap on the Amplifier monitor pane on the Home page. The Amplifier has a fixed gain that it applies to a user input signal. The signal is then routed to the RF input port of the MZM via the front panel loop-back cable.

There are two Modes for the amplifier: 1) Digital and 2) Analog, but both work with the same fixed gain. Analog mode simply sets the output swing of the amplifier to maximum.

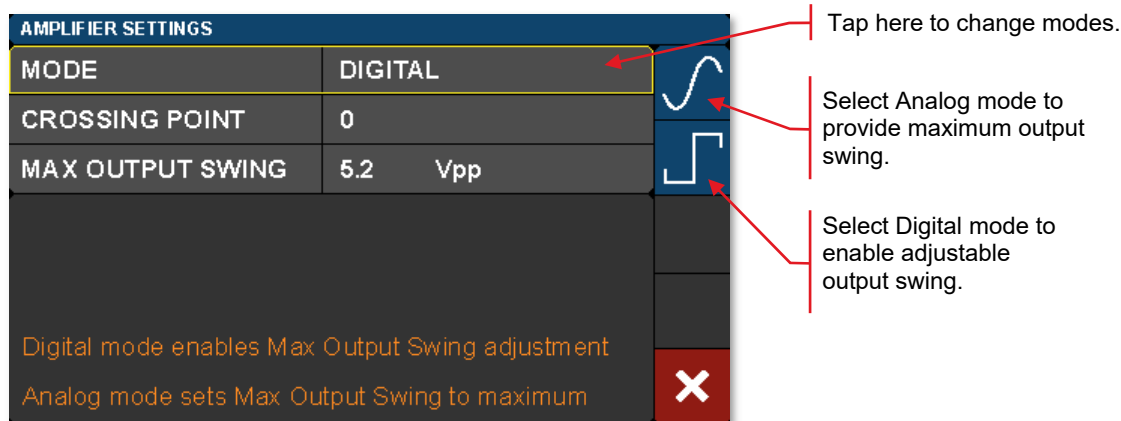

Figure 29 Selecting between Analog and Digital Amplifier Settings

The default amplifier mode is Digital, in which case the output swing and crossing point can both be adjusted while the gain is held constant. This digital mode is recommended for OOK (On-Off Keying) digital signals. The V_{π} Swing button is provided to conveniently set the Max Output Swing to the optimum value to achieve high extinction modulation with the internal modulator.

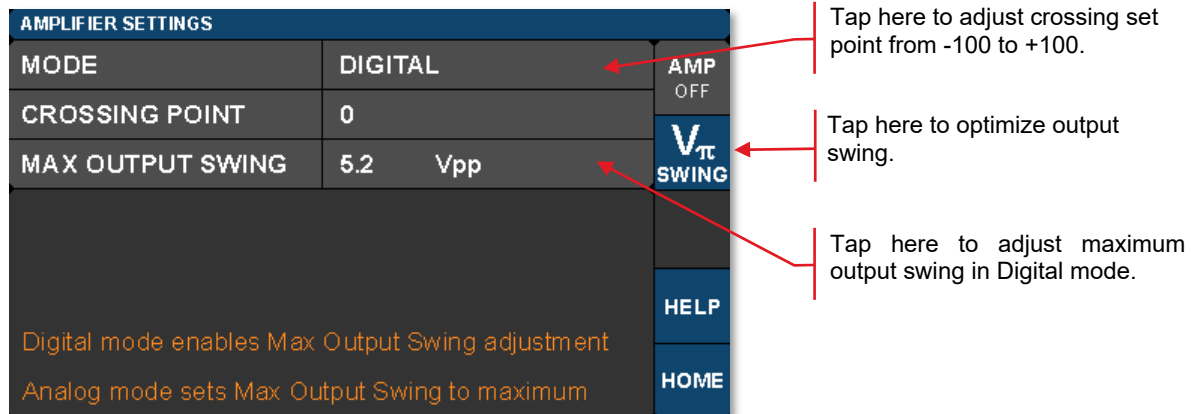

Figure 30 Digital Amplifier Mode Settings

The Max Output Swing field allows the user to set the peak-to-peak output voltage of the amplifier, assuming the amplifier input signal is large enough to cause the amplifier to start clipping. The Max Output Swing essentially controls the output amplitude at which the amplifier starts clipping. When operating in the digital mode, it is expected the user will supply a signal with sufficient input amplitude to cause the amplifier to clip.

The Crossing Point field allows the user to adjust the eye crossing point in the eye diagram as depicted in the diagram below. It provides an adjustment to optimize the bit-error-rate (BER) performance of a transmission link by adjusting the amplifier's internal threshold levels.

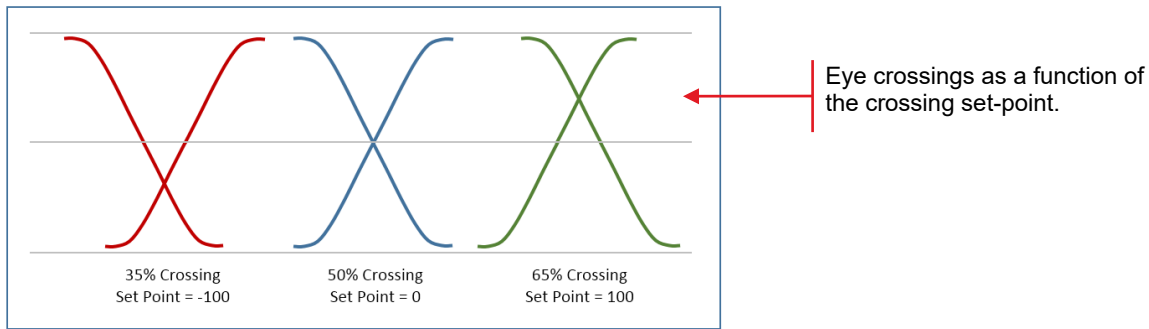

Figure 31 Illustration of Different Crossing Point Settings

In the Analog mode, the Max Output Swing is locked at the maximum set point of 7.0 V_{pp}, so the amplifier can drive the MZM linearly with minimal distortion. However, in order to do this, the user must supply a signal with small enough amplitude so the amplifier does not saturate, or clip. This mode is recommended for analog signals or higher order modulation formats such as PAM4. The crossing point adjustment can usually be left at 0, but the user may find other values achieve lower distortion. Maximum linear input is listed in the specifications.

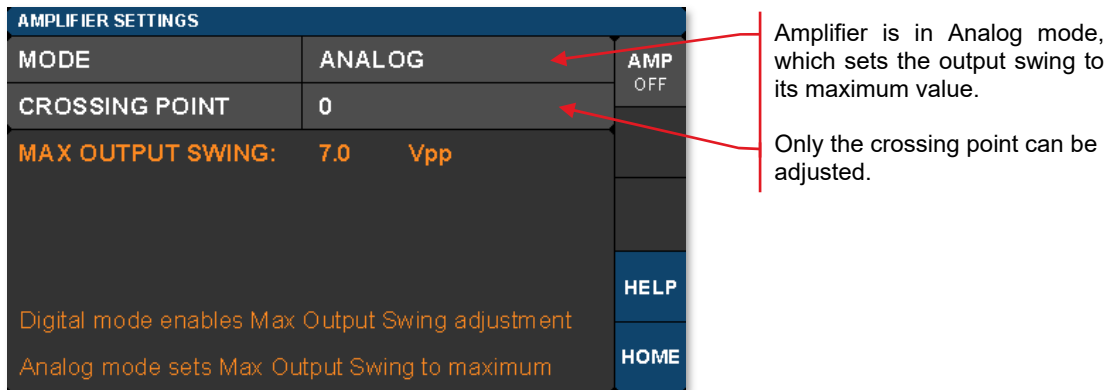

Figure 32 Amplifier Crossing Point Setting

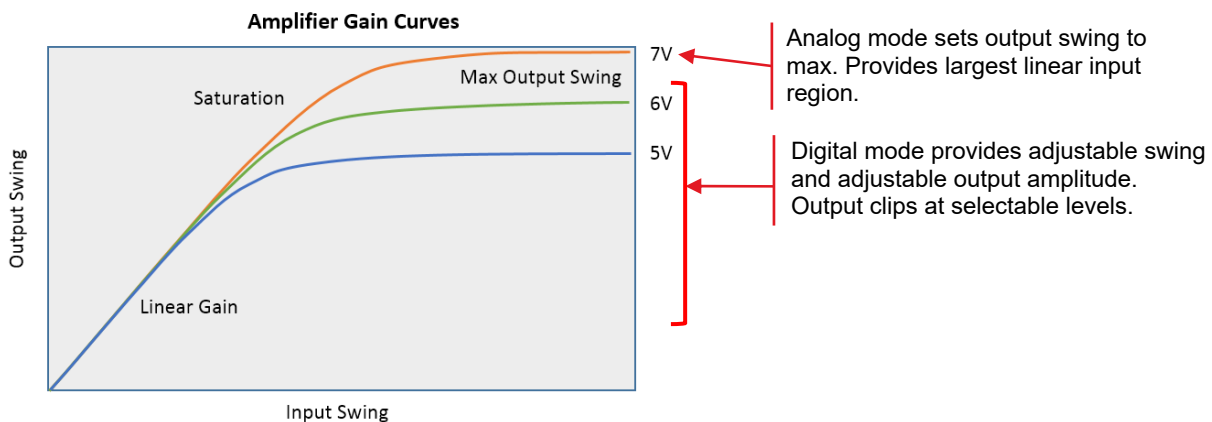

Figure 33 Amplifier Gain Curves Illustrate Difference between Digital and Analog Amplifier Modes

4.5 Variable Optical Attenuator Settings Page

To get to the Variable Optical Attenuator (VOA) Settings page, tap in the VOA monitors pane on the Home page. The VOA provides the means for adjusting and stabilizing the output power after the MZM. *Note that the power measurement units for the entire interface are set on this page.* The VOA can operate in either of two modes: 1) Constant Attenuation, and 2) Constant Output Power.

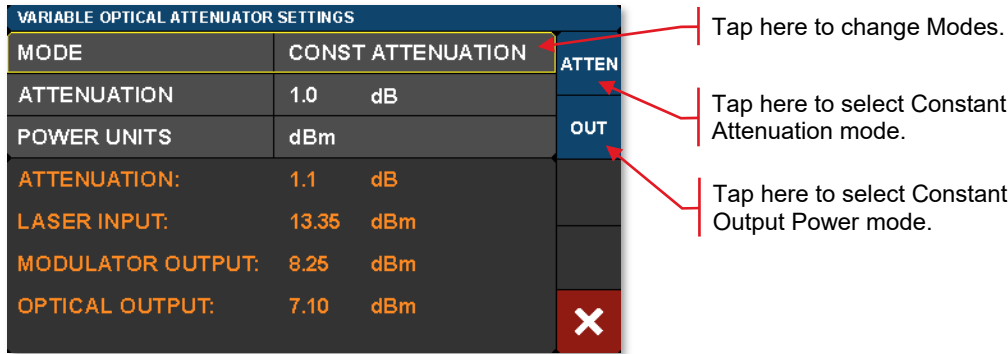

Figure 34 Constant Attenuation Mode of the VOA

Constant Attenuation Mode maintains a fixed attenuation level between the output of the MZM and the output port on the front panel. Any fluctuations at the input are transferred to the output.

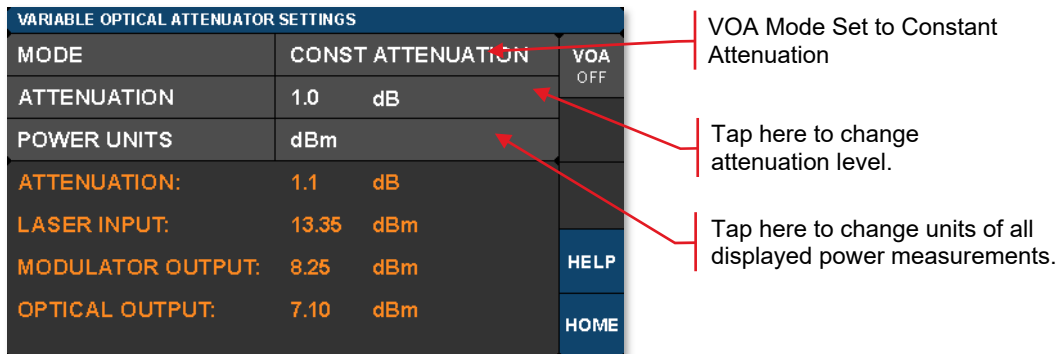

Figure 35 Constant Attenuation Mode Settings

Constant Output Power Mode acts as a stabilizer by holding the final optical power constant independent of input fluctuations (within controllable limits such as input power and attenuation).

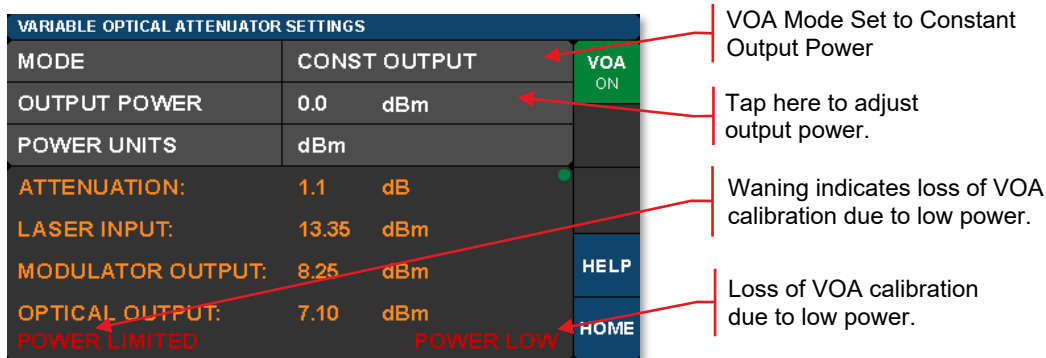

Figure 36 Constant Optical Output Mode of the VOA

4.6 Laser Settings Page



To access the Laser Settings page, tap on the Laser monitors pane on the Home page. Here the user can control the laser wavelength and choose whether or not to use the dither feature to stabilize the wavelength (available for models with C- or L-band lasers only). Turning the dither off will result in lower phase and intensity noise, but the wavelength may drift slightly over time. The monitors on this page provide live readings of many parameters.

Caution: The laser should not be turned on unless there is an optical fiber connected to the laser out port.

Optical frequency can be set at increments of 50 GHz for C-band or L-band tunable internal lasers. C-band and L-band lasers also support a fine tuning frequency offset feature, allowing the frequency to be adjusted by an offset from -30.000 GHz to +30.000 GHz. The ITU channel number on these pages is an index number given only for convenience, which is unique to this instrument; actual frequencies and spacings are specified by the ITU standard.

To adjust the ITU channel, tap on the ITU CHANNEL row and use the arrow buttons to increment or decrement the channel. Press the green check mark to accept the new channel, or the red cancel button to abort the change. You may also use the adjustment knob. Note that you are initially editing by channel, as indicated by the STEP CHAN button. Note that the frequency and wavelength value are estimated based on the laser's nominal 50 GHz channel spacing, not measured by the instrument.

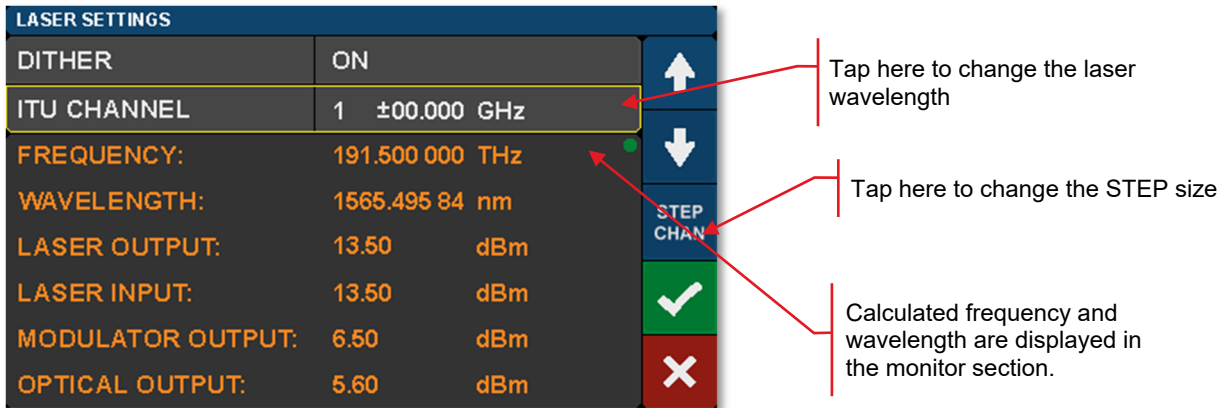

Figure 37 Changing the ITU Channel Number

To apply a fine-tuning frequency offset, tap the STEP CHAN button. The button will cycle to the next mode, STEP 10GHz. In this mode, using the up or down arrows or control knob will adjust the most significant digit of the frequency offset. Tapping the button repeatedly will cycle through the STEP 1GHz, STEP 100MHz, STEP 10MHz, and STEP 1MHz modes, allowing you to edit the offset in finer units of 1GHz, 100MHz, 10MHz, or 1MHz. Tapping the button one more time will cycle back to STEP CHAN mode.

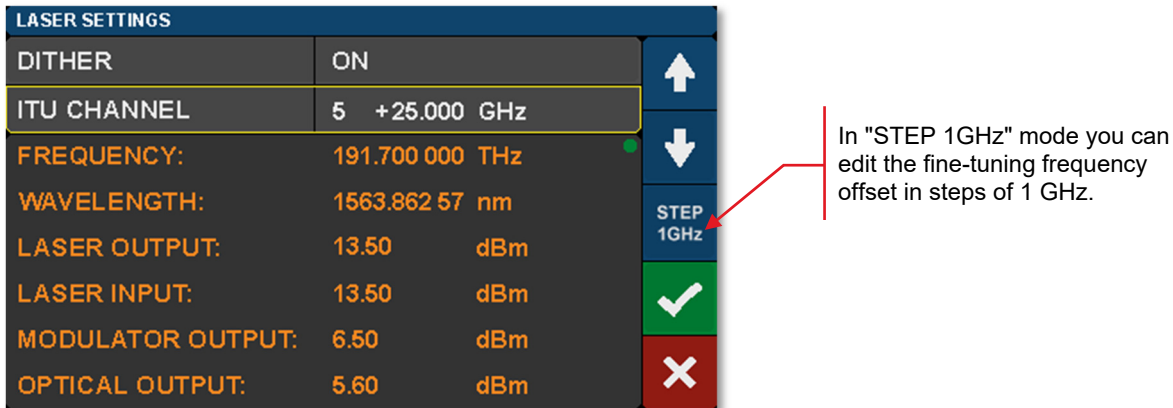

Figure 38 Changing the Fine-Tuning Step Size

Note that while the L-band and C-band lasers can have their frequency adjusted by increments as small as 1 MHz, the laser's actual tuning accuracy is not this fine. See Section 5.5 below for more information.

To turn the dither setting on or off, tap on the DITHER row and use the ON or OFF buttons to change the setting, or the red cancel button to abort the change.

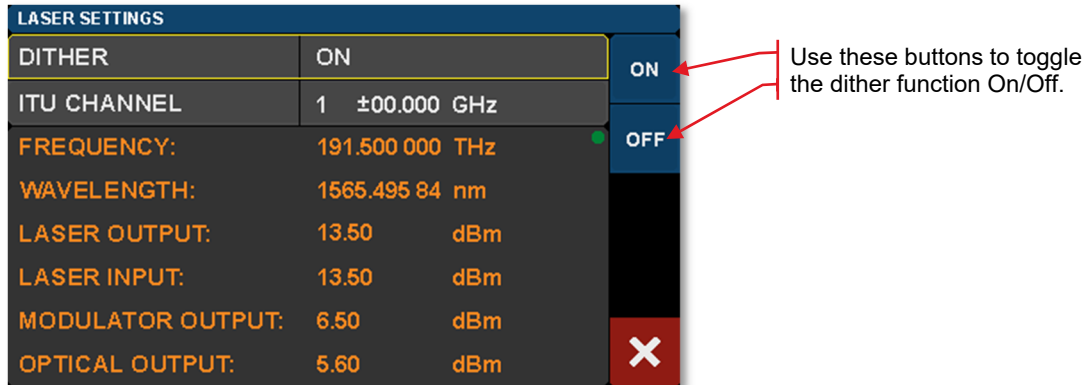

Figure 39 Enabling and Disabling Laser Dither

Figure 40 shows laser frequency noise as a function of optical frequency when the laser is operated with and without dither enabled. The red trace shows low noise operation when dither is turned off. Wavelength stability is improved by operating with dither, but the blue trace shows that this comes at the expense of added noise.

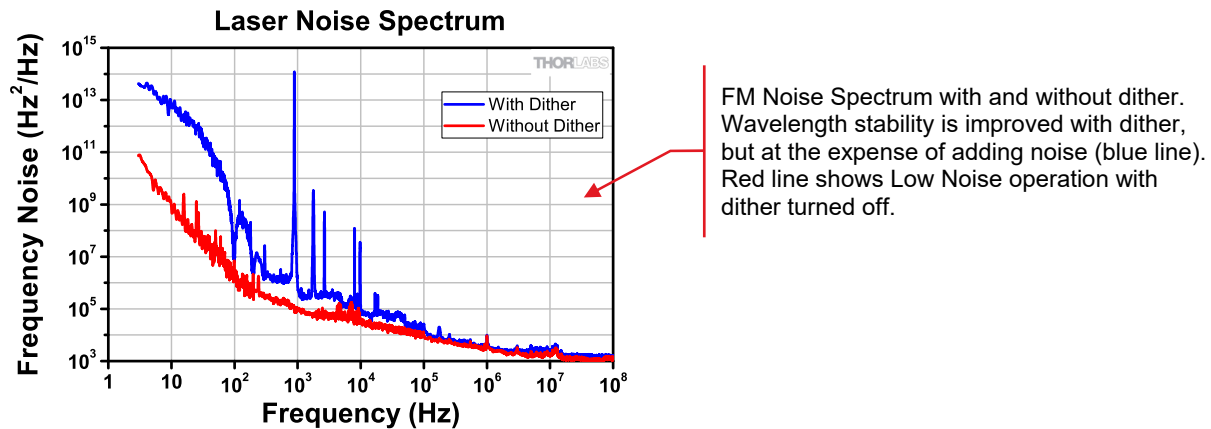

Figure 40 FM Noise Spectrum of the Laser

4.7 Load Page

To get to this page, tap the blue Load button on the Home page. The Load page has several instrument settings stored as presets for operating the instrument in different standard modes. Applying a preset is a fast way to put the instrument in a known state. Future firmware revisions will have the ability to store instrument states defined by the user as well.

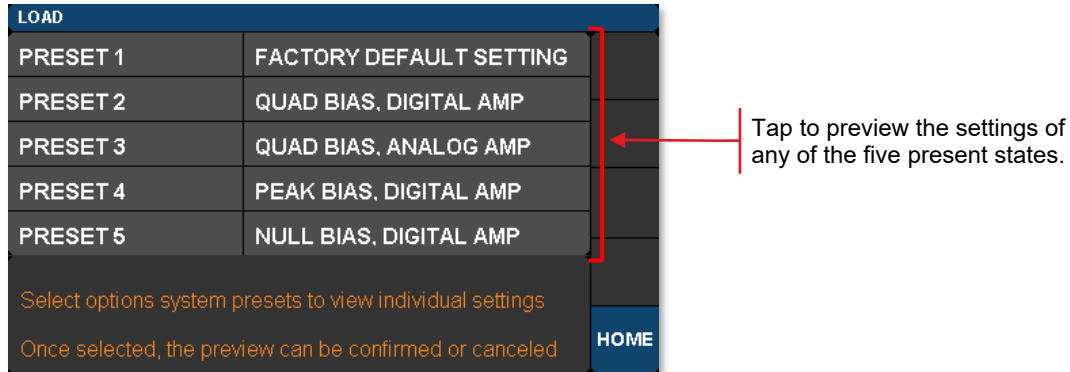

Figure 41 Preset State Options on the Load Page

Tapping on one of the presets will bring up a window that displays all the stored settings. The user can then review the choice before confirming with the green check-mark.

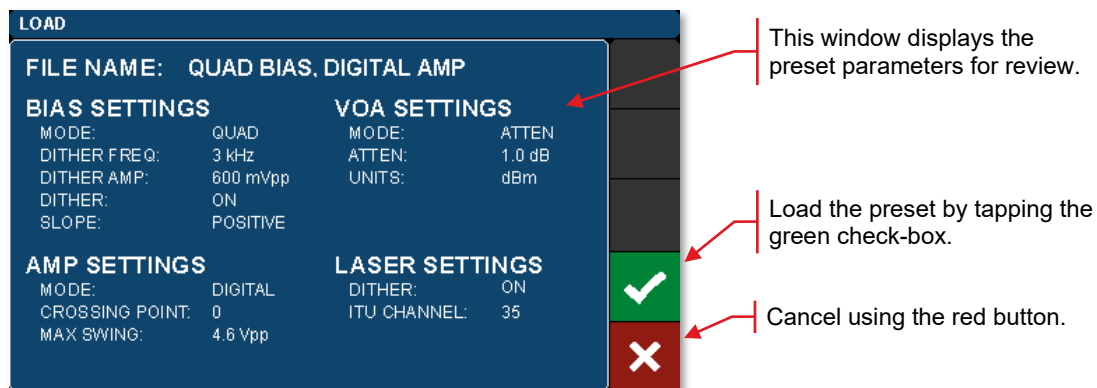

Figure 42 Reviewing the Parameter Values Set by a Preset State

4.8 Menu Page

To get to this page tap the blue Menu button on the Home page. The Menu page has links to several pages that allow the user to control the display, sounds, lights, and get help information. The following sections describe these functions in more detail.

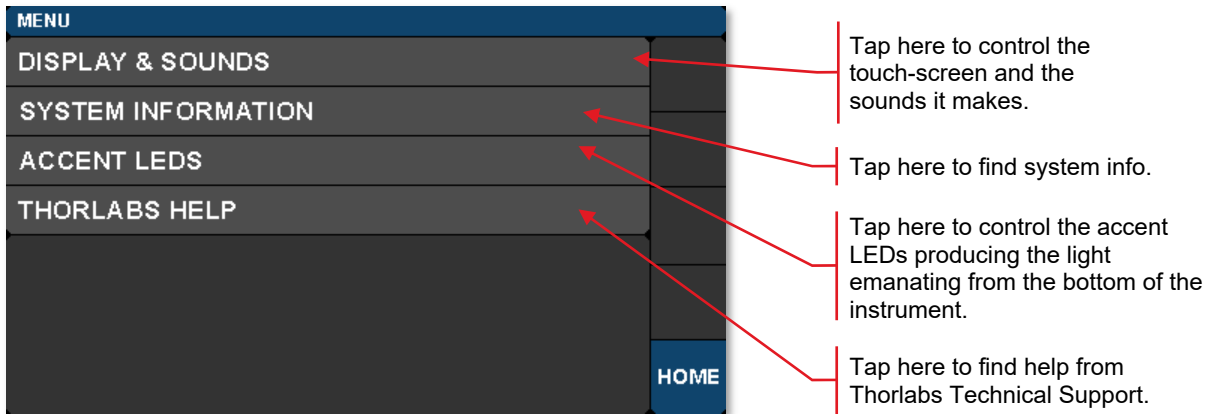

Figure 43 Controls on the Menu Page

4.8.1 Display and Sound Settings Page

To open the screen shown below, tap the DISPLAY AND SOUNDS button on the Menu pane.

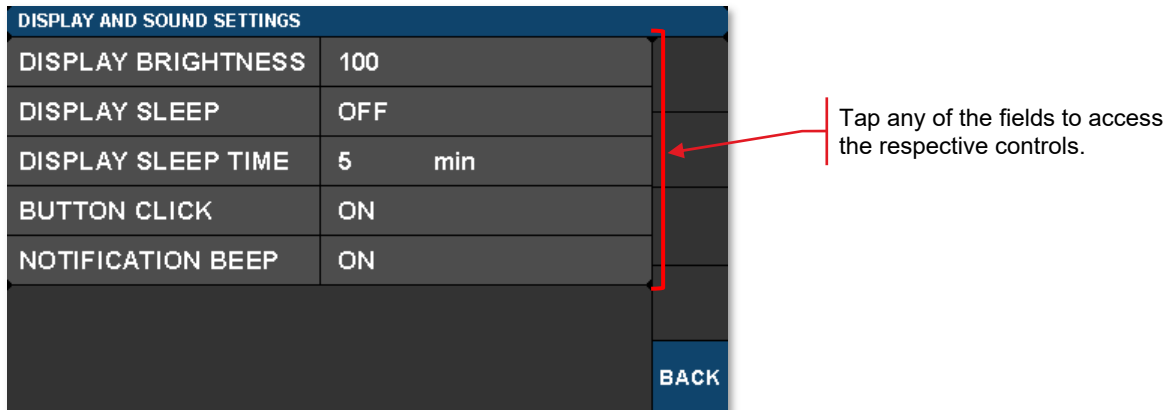

Figure 44 Display and Sound Settings Page

DISPLAY BRIGHTNESS controls the overall brightness of the touch-screen display

DISPLAY SLEEP TIME controls how long the touch-screen display is visible before it sleeps

BUTTON CLICK toggles the sound produced when tapping buttons (On/Off)

NOTIFICATION BEEP toggles the sound associated with certain on screen notifications (On/Off)

4.8.2 System Information Page

To open the screen shown below, tap the SYSTEM INFORMATION button on the Menu pane.

The System Information page displays the installed hardware and software versions.

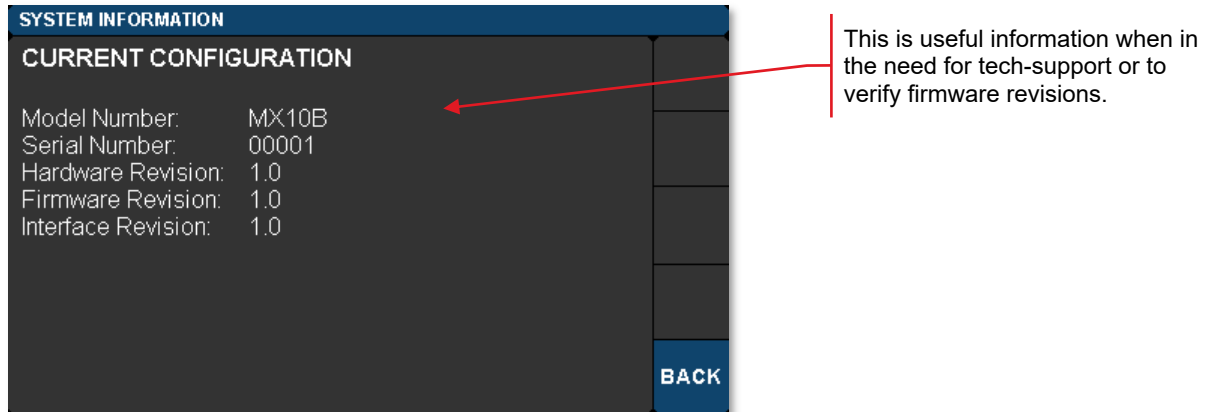

Figure 45 System Information Page

4.8.3 Accent LED Settings Page

To open the screen shown below, tap the ACCENT LEDES button on the Menu pane.

The accent LED settings control the intensity of the color LEDs that emanate from the bottom of the instrument. These are a fun aesthetic feature. You can set them to your favorite color.

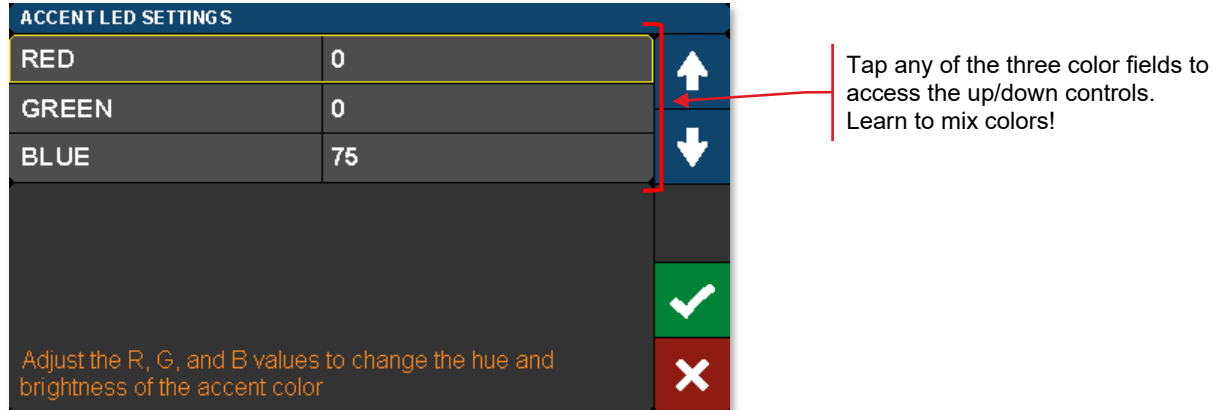

Figure 46 Controls to Adjust the LEDs Providing the Under-Instrument Accent Light

4.8.4 Thorlabs Help Page

To open the screen shown below, tap the THORLABS HELP button on the Menu pane.

The Thorlabs Help page displays the Tech Support phone number, Thorlabs web site, and the installed hardware and software versions. This information will be useful when speaking with Tech Support.

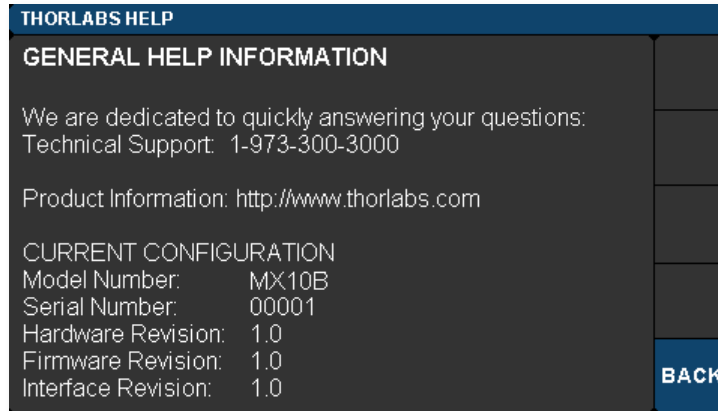

Figure 47 Thorlabs Help Page

Chapter 5 Specifications

All Specifications are at 1550 nm and 25 °C ambient temperature, unless otherwise noted. Specifications that are specific to the MX10B or MX40B series will be marked as such.

5.1 General System Specifications

Parameter		Typical Values	Notes
Max Laser Output Power		13.5 dBm	From Internal Laser
Max Optical Input Power		20 dBm	22 dBm Absolute Maximum, From External Laser
Optical Output Power ^{1,2}		8.5 dBm at 1550 nm 6.5 dBm at 1310 nm	Biased for Peak Optical Output
Internal Laser Wavelength Range ³	MX10B, MX40B	C-Band	Tunable in 50 GHz Steps
	MX10B-LB, MX40B-LB	L-Band	Tunable in 50 GHz Steps
	MX10B-1310, MX40B-1310	1310 nm	Fixed-Wavelength
External Laser Wavelength Range ⁴		1250 nm – 1610 nm	-
Calibrated Wavelengths		1310 nm, 1550 nm, 1590 nm	User Selectable
Max Bit Rate (Digital)	MX10B Series	12.5 Gb/s	Large, Digital Signal
	MX40B Series	40 Gb/s	
RF Optical Extinction Ratio		13 dB	At Max Bit Rate
Small Signal Bandwidth	MX10B Series	7 GHz	Linear, Analog Response
	MX40B Series	20 GHz	
Low Frequency Cutoff		100 kHz	-
Amplifier RF Input (Analog Mode)	MX10B Series	100 mV _{pp} Max	<5% THD at 1 GHz
	MX40B Series	120 mV _{pp} Max	
Amplifier RF Input (Digital Mode)	MX10B Series	400 mV _{pp} Typical	3.5 V Max; 4 V Absolute Max
	MX40B Series	400 mV _{pp} Typical	4 V Max; 6 V Absolute Max

¹ Specified when using internal laser and supplied loopback cable.

² Output power is typically 3 dB lower when bias is set at quadrature point.

³ An 850 nm fixed-wavelength laser can be substituted upon request: contact Thorlabs' technical support.

⁴ Using the modulator at another wavelength (e.g. visible light) may cause an increase in insertion loss and will void the warranty.

Parameter		Typical Values	Notes
Amplifier RF Output Swing		3 V _{pp} – 7 V _{pp}	Adjustable Swing (Accessible to User on MX10B Series Only)
Amplifier DC Input, Max	MX10B Series	±15 V	Input is AC-Coupled
	MX40B Series	±10 V	
Modulator RF Input ⁵		5.5 V _{pp} Typical, 7 V _{pp} Max	10 V Absolute Max (MX10B Series Only)
Modulator V _π		5.5 V _{pp}	At 1 GHz
Modulator EO Bandwidth ⁶		14 GHz	-3dB (MX10B Series Only)
Optical Insertion Loss		5.0 dB at 1550 nm 7.0 dB at 1310 nm	Laser IN to Optical OUT

5.2 Power and Environmental Specifications

Parameter	Min	Max
Main AC Voltage	100 VAC	250 VAC
Power Consumption	-	60 VA
Line Frequency	50 Hz	60 Hz
Operating Temperature	10 °C	40 °C
Storage Temperature	0 °C	50 °C
Humidity	5% RH	85% RH

5.3 Internal Control Specifications

Parameter	Typical	Notes
Power Monitors Accuracy	±0.5 dBm	At 1550 nm
Power Monitors Resolution	0.01 dBm	-
Power Monitor Insertion Loss	0.1 dB Typical	Per Monitor
VOA Attenuation Range	1 dB - 20 dB	-
VOA Response Time	1 s	-

⁵ Quoted only for the MX10B series. The external loop-back between output of the RF amplifier and the internal modulator is accessible to the operator in the MX10B series of transmitters, but the connection is made directly inside the housing of the MX40B series.

⁶ Internal modulator RF input is only accessible on the MX10B Series transmitters.

5.4 Internal Amplifier Specifications

Parameter		Typical Values	Notes
Rise/Fall Time	MX10B Series	35 ps	Large Signal, Digital Response
	MX40B Series	8 ps	
RF Amplifier Gain	MX10B Series	34 dB	-
	MX40B Series	30 dB	
Small Signal Bandwidth	MX10B Series	7 GHz	Linear, Analog Response
	MX40B Series	20 GHz	
RF Amplifier Max Output Swing		$3 V_{pp} - 7 V_{pp}$	Adjustable Swing
Low Frequency Cutoff		100 kHz	-
Electrical Return Loss		-10 dB	Any RF Port (to -3 dB BW)

5.5 Laser Specifications

Parameter	Unit	Min	Typ.	Max
C-Band Tunable Laser (MX10B, MX40B)				
Optical Output Power	dBm	12.5	13.5	14.5
Frequency Range	THz	191.50	-	196.25
Wavelength Range	nm	1527.6	-	1565.5
Frequency Accuracy	GHz	-1.5	-	1.5
Tuning Resolution	GHz	-	50	-
Tuning Speed (Between Wavelengths)	s	-	10	-
Fine Tuning Resolution	MHz	-	1	-
Fine Tuning Speed	GHz/s	-	1	-
Fine Tuning Range	GHz	-30	-	30
Side Mode Suppression Ratio (SMSR)	dB	40	55	-
Optical Signal to Noise Ratio (OSNR)	dB	40	60	-
Intrinsic Linewidth	kHz	-	10	15
Relative Intensity Noise (RIN)	dB/Hz	-	-	-145
Back Reflection	dB	-	-	-14
Polarization Extinction Ratio (PER)	dB	18	-	-
L-Band Tunable Laser (MX10B-LB, MX40B-LB)				
Optical Output Power	dBm	12.5	13.5	14.5
Frequency Range	THz	186.35	-	190.95
Wavelength Range	nm	1570.0	-	1608.8
Frequency Accuracy	GHz	-1.5	-	1.5
Tuning Resolution	GHz	-	50	-
Tuning Speed (Between Wavelengths)	s	-	10	-
Fine Tuning Resolution	MHz	-	1	-
Fine Tuning Speed	GHz/s	-	1	-
Fine Tuning Range	GHz	-30	-	30
SMSR	dB	40	55	-
OSNR	dB	40	60	-
Intrinsic Linewidth	kHz	-	10	15
RIN	dB/Hz	-	-	-145
Back Reflection	dB	-	-	-14
PER	dB	18	-	-
1310 nm Fixed-Wavelength Laser (MX10B-1310, MX40B-1310)				
Optical Output Power	dBm	12.5	13.5	14.5
Wavelength	nm	-	1310	-
SMSR	dB	35	-	-
Intrinsic Linewidth	MHz	-	2	3
PER	dB	-	20	-

Chapter 6 Control and PC Connections

6.1 General Purpose I/O, RS-232, and USB Connections

The back panel has connectors for monitor and control functions, as well as for upgrading the firmware. Both the RS-232 and the USB connections can be used for remotely controlling the MX10B and MX40B series via SCPI type serial commands. Which connector to choose for remote control operation depends on the demands of the application and the user's preference. See the remote control user guide (RCUG), which can be downloaded from <https://www.thorlabs.com/manuals.cfm>, for information about the commands and connecting the unit to a PC.

The most recent firmware and remote control software tool are available through Thorlabs' website: please visit https://www.thorlabs.com/navigation.cfm?Guide_ID=2191 and enter the Item # into the search field. The instrument's firmware can be updated by uploading the new version from a PC via the USB port. Thorlabs' technical support can provide up-to-date information on available firmware revisions and control functions.

The 15-pin I/O connector provides outputs from the power monitors in the optical path (see the block diagram in Chapter 3). The power monitors provide a voltage that is proportional to the optical power with one of two gain settings. These values are available on the I/O DB15 connector. The gain setting for each monitor is determined by software, and reported on the corresponding Gain Indicator pins. 0.0 V indicates Low Gain (40 V/W) and 3.3 V indicates High Gain (4000 V/W). Maximum output voltage at the monitor pin is less than 12 V (into a high impedance). Power monitor bandwidth is limited to about 150 Hz.

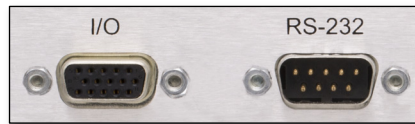

Figure 48 15-Pin I/O and RS-232 Connectors on the Back Panel

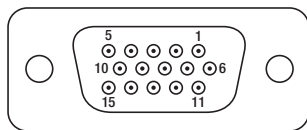

Figure 49 15-Pin I/O Connector Pin Configuration

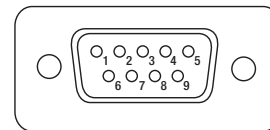

Figure 50 RS-232 Connector Pin Configuration

I/O Conn.	Pin #	Description
HD DB15	1	Power Monitor 1 (Mon-1)
HD DB15	2	Power Monitor 2 (Mon-2)
HD DB15	3	Power Monitor 3 (Mon-3)
HD DB15	4	Reserved for Future Use
HD DB15	5	Analog Ground
HD DB15	6	Analog Ground
HD DB15	7	Analog Ground
HD DB15	8	Analog Ground
HD DB15	9	Analog Ground
HD DB15	10	Analog Ground
HD DB15	11	Reserved for Future Use
HD DB15	12	Reserved for Future Use
HD DB15	13	Power Monitor 1 (Mon-1) Gain Indicator
HD DB15	14	Power Monitor 2 (Mon-2) Gain Indicator
HD DB15	15	Power Monitor 3 (Mon-3) Gain Indicator

RS-232	Pin #	Description
DB9	1	Not Connected
DB9	2	RS-232 Input
DB9	3	RS-232 Output
DB9	4	Not Connected
DB9	5	Digital Ground
DB9	6	Not Connected
DB9	7	Not Connected
DB9	8	Not Connected
DB9	9	Not Connected

6.2 The Laser Safety Interlock

The instrument is equipped with a remote interlock connector located on the rear panel. In order to enable the laser source, a short circuit must be applied across the terminals of the Remote Interlock connector. In practice this connection is made available to allow the user to connect a remote actuated switch to the connector. The switch (which must be normally open) has to be closed in order for the laser to be enabled. If the switch changes to an open state, the laser source will automatically shut down. If the switch returns to a closed condition the laser source must be turned on again in the touchscreen GUI.

All units shipped from Thorlabs are configured with a shorting device installed in the Interlock connector. If you are not going to use this feature, then leave the shorting device installed. The unit will operate normally as described in the procedures above.

If you wish to make use of the Interlock feature you will need to acquire the appropriate 2.5 mm plug, wire it to the remote interlock switch, and then plug it in to the back-panel interlock jack in place of the shorting plug. This type of plug is readily available at most electronics stores. The electrical specifications for the interlock input are shown in the following table.

Specification	Value
Type of Mating Connector	2.5 mm Mono Phone Jack
Open Circuit Voltage	<5 VDC (On Barrel of Plug)
Short Circuit Current	7 mA (Typical)
Connector Polarity	Tip is Ground, Barrel is at 5 VDC Max
Interlock Switch Requirements	Must be normally open dry contacts Apply no external voltages to the interlock input

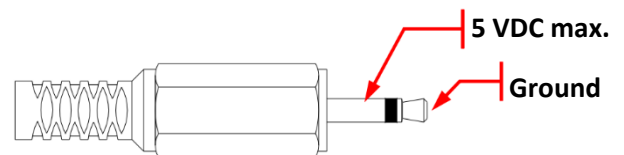

Chapter 7 Mechanical Drawings

7.1 MX10B Series

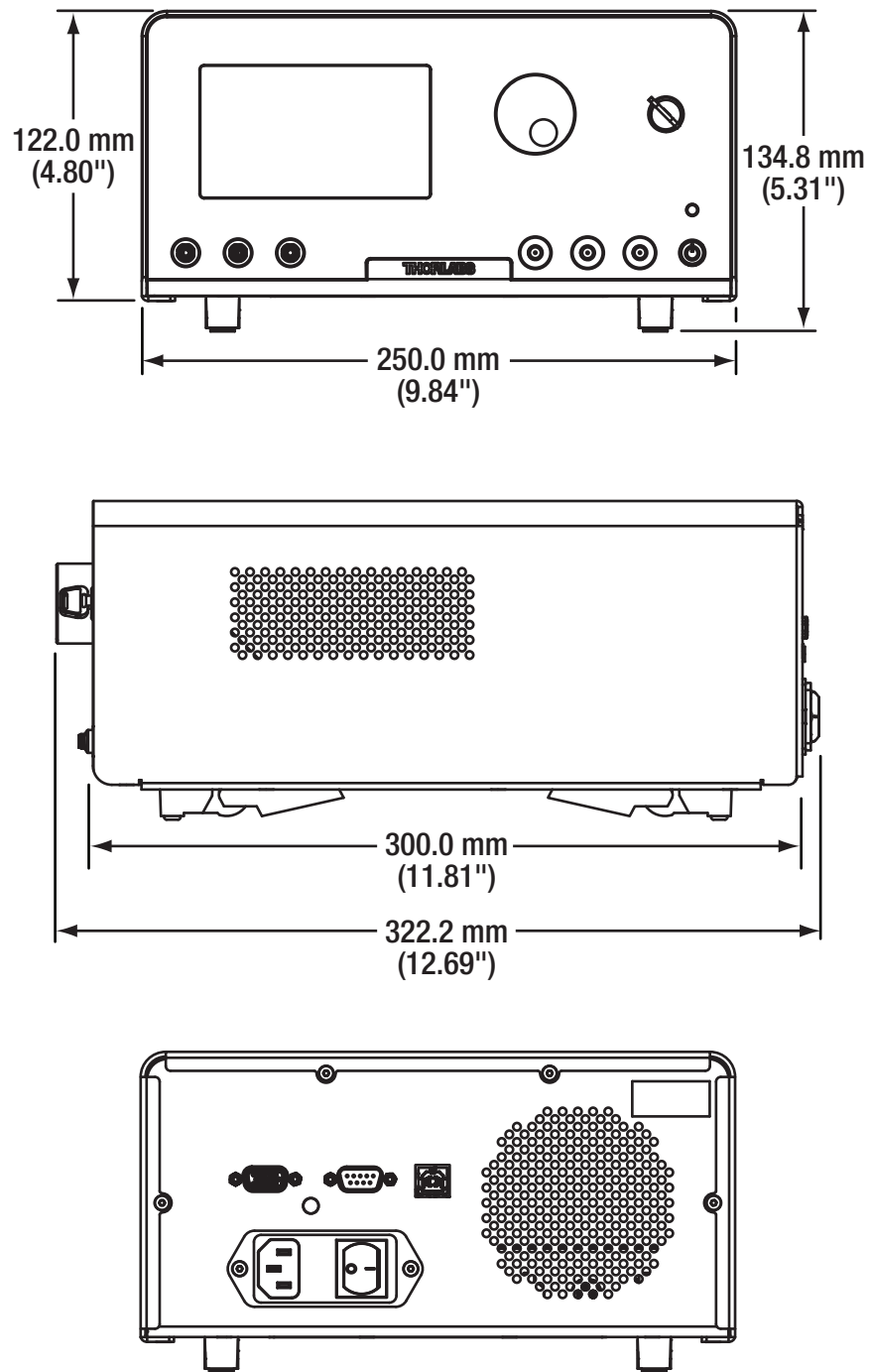

Figure 51 Mechanical Drawing of the MX10B Series

7.2 MX40B Series

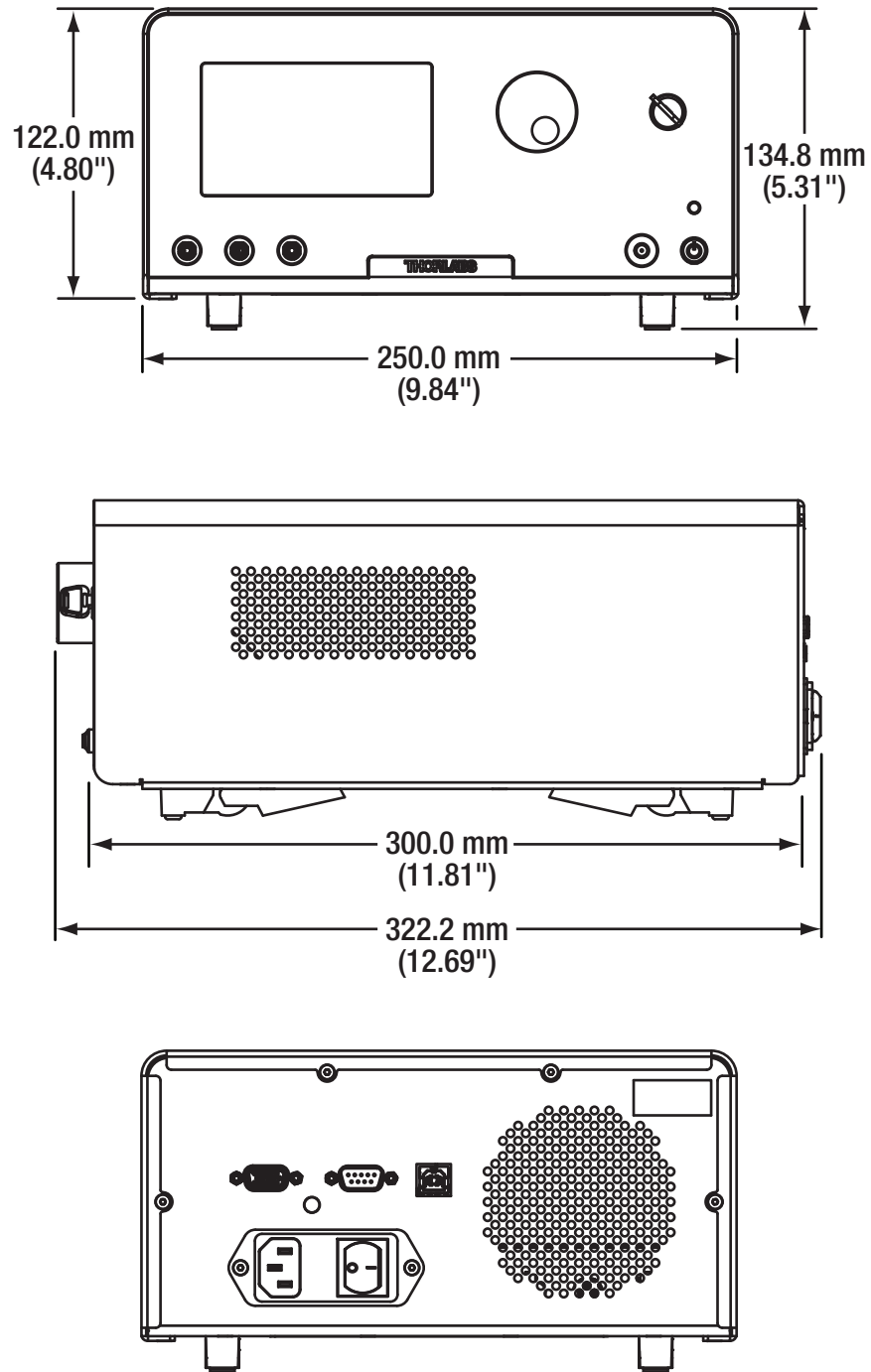

Figure 52 Mechanical Drawing of the MX40B Series

Chapter 8 Maintenance, Repair, and Fuses

8.1 Maintenance and Repair

The instrument should not need regular maintenance by the user. If necessary the display, housing, and front panel can be cleaned using a soft cloth moistened with normal, mild glass cleaner. Do not use any chemical solvents or harsh cleaners on the display. Do not spray any cleaning solutions directly onto any part of the unit.

The instrument does not contain any modules that can be repaired by the user. If a malfunction occurs, please contact Thorlabs Technical Support and arrangements will be made to investigate the problem. Do not remove the cover. There are no user serviceable components inside.

Optical patch cords used to connect to the front panel of the instrument should have their end faces cleaned every time a new connection is made. The end faces of the internal fiber connectors can easily be damaged by the use of dirty fiber ends. If damage occurs, the instrument will need to be sent back for repair. We suggest using a fiber end-face cleaning product such as the Thorlabs FCC-7020 shown below. Alternatively, a lint-free cloth moistened with isopropyl alcohol or methanol can be used. Never use acetone.

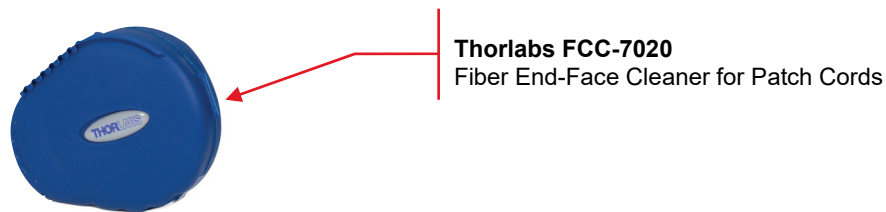

Thorlabs FCC-7020
Fiber End-Face Cleaner for Patch Cords

The optical connectors on the front panel may be cleaned using a 2.5 mm bulkhead cleaner such as the Thorlabs FBC250. This allows the user to clean the fiber end-face without removing it from the internal bulkhead adapter.



Thorlabs FBC250
Fiber End-Face Cleaner for Bulkheads

8.2 Replacement Parts

The following parts can be obtained by contacting Thorlabs Technical Support

- SMA 50 Ω Loads (Used for Front Panel RF Connectors)
- PM Loopback Fiber Patch Cord for Front Panel
- SMA Loopback RF Cable (Not in MX40B Series)
- Laser Interlock Keys for Front Panel Switch
- 2.5 mm Interlock Pin (for Back Panel)
- 1.25 A 250 VAC Fuse for Main Power
- Instrument IEC Main Power Cord

8.3 Replacing the Main Fuse

The system is protected by a main fuse located in the power entry module where the main power cable plugs into the back panel of the instrument. If the instrument does not appear to power-up, especially after a power outage or storm, you can check the condition of the main power fuse without removing the cover of the instrument by following the following steps.

1. Put the instrument in “Standby” mode by pressing the standby button on the front of the instrument. Wait until the button turns from green to amber.
2. Turn the power off using the switch on the back panel of the instrument.
3. Unplug the main power cable.
4. Carefully remove the fuse holder slide from the power entry module (use a flat screwdriver)

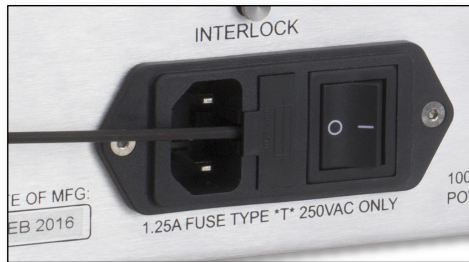

Figure 53 Power Entry Module



Figure 54 Removing the Fuse Holder Slide

Investigate the fuse. This can be done with a simple continuity check. If in doubt, replace the fuse. A spare fuse is stored in the fuse holder. Additional replacement fuses can be purchased from Thorlabs. **Always use fuses of the same type as the original.**



Figure 55 Fuse

1. Reinstall the fuse holder slide into the power entry module, taking care that it fully seats until the top is flush with the rest of the power entry module.
2. Plug the main power cable back into the unit and power on as described in the *Getting Started* section of the manual.

If the fuse blows repeatedly, it is likely that an internal failure has occurred. Do not attempt to bypass the fuse as this can create a dangerous situation that could further damage the instrument or harm personnel. In this case, please contact Technical Support for directions.

Chapter 9 Troubleshooting

Below is some information about status indicators and a few checks to help in troubleshooting general problems. If you have any questions, please contact your local Thorlabs Technical Support office.

If the unit does not appear to turn on correctly, please check the following items:



- Ensure that the main AC receptacle is powered
- Ensure that main power cable is fully seated at both ends
- Ensure that back power switch is in the "I" position
- Check the main power fuse (see Maintenance and Repair Section)



The color of the Standby Button, which is on the front panel, indicates several status conditions as follows:

Standby Button Color	Condition
Solid Green	Indicates normal ON state.
Solid Amber	Indicates unit is in Standby Mode. Press the button to turn the instrument ON.
Blinking Green	Indicates the main AC power is unstable. When the AC power is restored, the instrument will return to the standby mode (amber).
Blinking Amber	Indicates the instrument is overheated. Make sure the fan is running and none of the vents are blocked. If there are no ventilation issues, then the box should cool itself and return to the standby. Do not operate, or leave the instrument in standby mode, in an environment above 40 °C.
Blinking Amber/Green	Indicates the instrument is both overheated and the main AC power is unstable (see individual troubleshooting for these conditions above).
Fading Amber/Green	Indicates the instrument is in the firmware upgrade mode. If this condition appears after attempting to upgrade the firmware, the update may have failed, or the unit may have been left in the update mode. Try running the firmware update again. This condition may have also been reached by holding down the standby button for a long time while turning on the power. In this case, turn the unit off, wait for a few seconds, and turn it back on. If this condition for any other reason, turn the unit off, wait for a few seconds, and turn it back on. If these attempts to recover continue to fail, the instrument's firmware may have been corrupted. Contact Tech Support for help.

If the optical power at any point of the system is lower than expected, resolving the problem always starts by cleaning the optical fiber ends. Contaminated fiber ends, which attenuates the intensity of the transmitted light, is a very common issue when using single-mode fibers. Follow the suggestions provided in the Maintenance and Repair section of this manual to clean the optical fiber ends.

Chapter 10 Declarations of Conformity

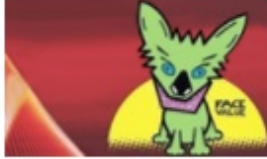
		<h1>THORLABS</h1> <p>www.thorlabs.com</p>	
<h2>EU Declaration of Conformity</h2> <p><i>in accordance with EN ISO 17050-1:2010</i></p>			
We:	Thorlabs Inc.		
Of:	56 Sparta Avenue, Newton, New Jersey, 07860, USA		
<i>in accordance with the following Directive(s):</i>			
2014/35/EU	Low Voltage Directive (LVD)		
2014/30/EU	Electromagnetic Compatibility (EMC) Directive		
2011/65/EU	Restriction of Use of Certain Hazardous Substances (RoHS)		
2009/125/EC	Eco-Design Directive		
<i>hereby declare that:</i>			
Model:	MX10B, MX10B-LB, MX10C, MX10C-LB, MX10B-1310, MX10C-1310		
Equipment:	12.5 Gb/s Optical Transmitter		
<i>is in conformity with the applicable requirements of the following documents:</i>			
EN 61010-1	Safety Requirements for Electrical Equipment for Measurement, Control and Laboratory Use - EMC Requirements 2010		
EN 61326-1	Electrical Equipment for Measurement, Control and Laboratory Use - EMC Requirements 2013		
EC No 1194/2012	Eco-Design Requirements for Directional Lamps, LED Lamps, & Related Equipment 2012		
<i>and which, issued under the sole responsibility of Thorlabs, is in conformity with Directive 2011/65/EU of the European Parliament and of the Council of 8th June 2011 on the restriction of the use of certain hazardous substances in electrical and electronic equipment, for the reason stated below:</i>			
does not contain substances in excess of the maximum concentration values tolerated by weight in homogenous			
<i>I hereby declare that the equipment named has been designed to comply with the relevant sections of the above referenced specifications, and complies with all applicable Essential Requirements of the Directives.</i>			
Signed:			On: 14 March 2016
Name:	Ann Strachan		
Position:	Compliance Manager	EDC - MX10B, MX10B-LB, MX10C, MX10C...	
			

		THORLABS	
		www.thorlabs.com	
<i>EU Declaration of Conformity</i>			
<i>in accordance with EN ISO 17050-1:2010</i>			
We:	Thorlabs Inc.		
Of:	56 Sparta Avenue, Newton, New Jersey, 07860, USA		
<i>in accordance with the following Directive(s):</i>			
2014/35/EU	Low Voltage Directive (LVD)		
2014/30/EU	Electromagnetic Compatibility (EMC) Directive		
2011/65/EU	Restriction of Use of Certain Hazardous Substances (RoHS)		
2009/125/EC	Eco-Design Directive		
 <i>hereby declare that:</i>			
Model:	MX40B, MX40B-LB, MX40C, MX40C-LB, MX40B-1310, MX40C-1310		
Equipment:	40 Gb/s Optical Transmitter		
<i>is in conformity with the applicable requirements of the following documents:</i>			
EN 61010-1	Safety Requirements for Electrical Equipment for Measurement, Control and Laboratory Use 2010		
EN 61326-1	Electrical Equipment for Measurement, Control and Laboratory Use - EMC Requirements 2013		
EC No 1194/2012	Eco-Design Requirements for Directional Lamps, LED Lamps, & Related Equipment 2012		
 <i>and which, issued under the sole responsibility of Thorlabs, is in conformity with Directive 2011/65/EU of the European Parliament and of the Council of 8th June 2011 on the restriction of the use of certain hazardous substances in electrical and electronic equipment, for the reason stated below:</i>			
does not contain substances in excess of the maximum concentration values tolerated by weight in homogenous			
 <i>I hereby declare that the equipment named has been designed to comply with the relevant sections of the above referenced specifications, and complies with all applicable Essential Requirements of the Directives.</i>			
Signed:		On:	14 March 2016
Name:	Ann Strachan		
Position:	Compliance Manager	EDC - MX40B, MX40B-LB, MX40C, MX40C...	

Chapter 11 Thorlabs Worldwide Contacts

For technical support or sales inquiries, please visit us at www.thorlabs.com/contact for our most up-to-date contact information.



USA, Canada, and South America

Thorlabs, Inc.
sales@thorlabs.com
techsupport@thorlabs.com

Europe

Thorlabs GmbH
europe@thorlabs.com

France

Thorlabs SAS
sales.fr@thorlabs.com

Japan

Thorlabs Japan, Inc.
sales@thorlabs.jp

UK and Ireland

Thorlabs Ltd.
sales.uk@thorlabs.com
techsupport.uk@thorlabs.com

Scandinavia

Thorlabs Sweden AB
scandinavia@thorlabs.com

Brazil

Thorlabs Vendas de Fotônicos Ltda.
brasil@thorlabs.com

China

Thorlabs China
chinasales@thorlabs.com

Thorlabs verifies our compliance with the WEEE (Waste Electrical and Electronic Equipment) directive of the European Community and the corresponding national laws. Accordingly, all end users in the EC may return "end of life" Annex I category electrical and electronic equipment sold after August 13, 2005 to Thorlabs, without incurring disposal charges. Eligible units are marked with the crossed out "wheelie bin" logo (see right), were sold to and are currently owned by a company or institute within the EC, and are not disassembled or contaminated. Contact Thorlabs for more information. Waste treatment is your own responsibility. "End of life" units must be returned to Thorlabs or handed to a company specializing in waste recovery. Do not dispose of the unit in a litter bin or at a public waste disposal site.

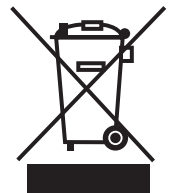

Annex I



THORLABS
www.thorlabs.com
