



NRT Series Motorized Translation Stage

User Guide



Original Instructions

Contents

Chapter 1	Introduction	1
Chapter 2	Safety.....	2
	2.1 Safety Information	2
	2.2 General Warnings and Cautions	2
Chapter 3	Installation and Operation.....	3
	3.1 Mounting to a Work Surface.....	3
	3.1.1 General.....	3
	3.2 Environmental Conditions.....	3
	3.2.1 Mounting a Single Stage to a Work Surface	4
	3.2.2 Mounting stages in X-Y configurations	5
	3.2.3 Mounting stages in X-Y-Z configurations	6
	3.3 Operation	8
	3.3.1 System Setup.....	8
	3.3.2 Selecting the Stage Type.....	8
	3.4 Calibration of Motor Drives	11
	3.5 Maintenance.....	11
Chapter 4	Specification.....	12
	4.1 Specification	12
	4.2 Pin Out.....	13
	4.3 Parts List.....	13
Chapter 5	Regulatory.....	14
	5.1 Declarations Of Conformity.....	14
	5.1.1 For Customers in Europe.....	14
	5.1.2 For Customers In The USA	14
Chapter 6	CE Certificate.....	15
Chapter 7	Thorlabs Worldwide Contacts.....	17

Chapter 1 Overview

1.1 Introduction

The NRT series stages are performance positioning stages which are ideally suited for measurement and inspection applications. The main platform is supported by 4 recirculating ball carrier bearings mounted to precisely aligned linear guide rails. A backlash free precision lead screw produces smooth translation, directly driven with a hybrid 2-phase stepper motor capable of 409,600 micro steps per revolution, and positioning resolutions of 0.1 μm when driven by the BSC series of benchtop controllers. The highly repeatable, Hall effect (magnetic) home detection limit switch also provides overdriving protection in both forward and reverse directions.

The high quality stepper motor offers excellent dynamic and static torque performance and the design provides the detailed features required of any true micro-positioning product.

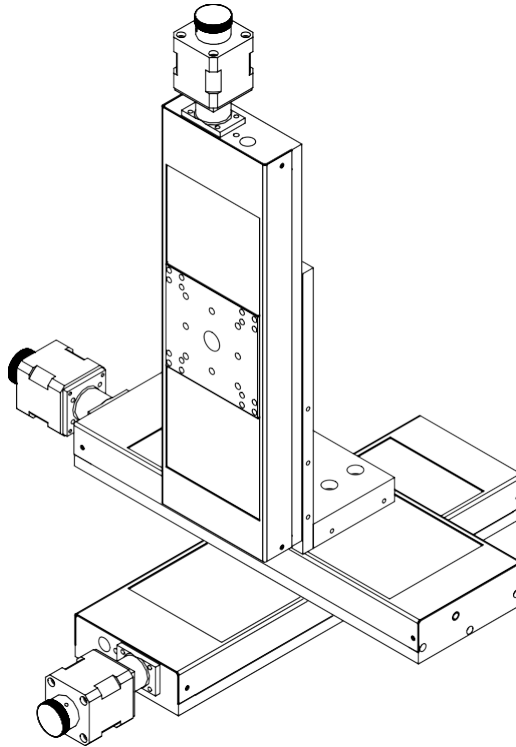

Fig. 1.1 Typical XYZ Configuration

Chapter 2 Safety

2.1 Safety Information

For the continuing safety of the operators of this equipment, and the protection of the equipment itself, the operator should take note of the **Warnings, Cautions** and **Notes** throughout this handbook and, where visible, on the product itself.

The following safety symbols may be used throughout the handbook and on the equipment itself.



Warning: Risk of Electrical Shock

Given when there is a risk of injury from electrical shock.



Warning

Given when there is a risk of injury to users.



Caution

Given when there is a risk of damage to the product.

Note

Clarification of an instruction or additional information.

2.2 General Warnings and Cautions



Warning

If this equipment is used in a manner not specified in the handbook, the protection provided by the equipment may be impaired. In particular, excessive moisture may impair operation.

Spillage of fluid, such as sample solutions, should be avoided. If spillage does occur, clean up immediately using absorbent tissue. Do not allow spilled fluid to enter the internal mechanism.

The equipment is for indoor use only.

When running custom move sequences, or under fault conditions, the stage may move unexpectedly. Operators should take care when working inside the moving envelope of the stage.

Chapter 3 Installation and Operation

Note

Retain the packing in which the unit was shipped, for use in future transportation.

3.1 Mounting to a Work Surface

3.1.1 General

When mounting the NRT stage close to other equipment, ensure that the travel of the moving platform is not obstructed. If equipment mounted on the moving platform is driven against a solid object, damage to the internal mechanism could occur. The range of travel for each model is as follows:

NRT100 – 100 mm; NRT150 – 150 mm.

3.2 Environmental Conditions



Warning

Operation outside the following environmental limits may adversely affect operator safety.

Location	Indoor use only
Maximum altitude	2000 m
Temperature range	5°C to 40°C
Maximum Humidity	Less than 80% RH (non-condensing) at 31°C

To ensure reliable operation the unit should not be exposed to corrosive agents or excessive moisture, heat or dust.

If the unit has been stored at a low temperature or in an environment of high humidity, it must be allowed to reach ambient conditions before being powered up.

The unit must not be used in an explosive environment.

3.2.1 Mounting a Single Stage to a Work Surface

The NRT stage is mounted to the working surface by M6 screws through the base. To access these mounting holes, turn the motor knob to move the carriage until the holes are visible through the center hole - see Fig. 3.1. The stage can also be mounted in other orientations - see Section 3.2.2. and 3.2.4

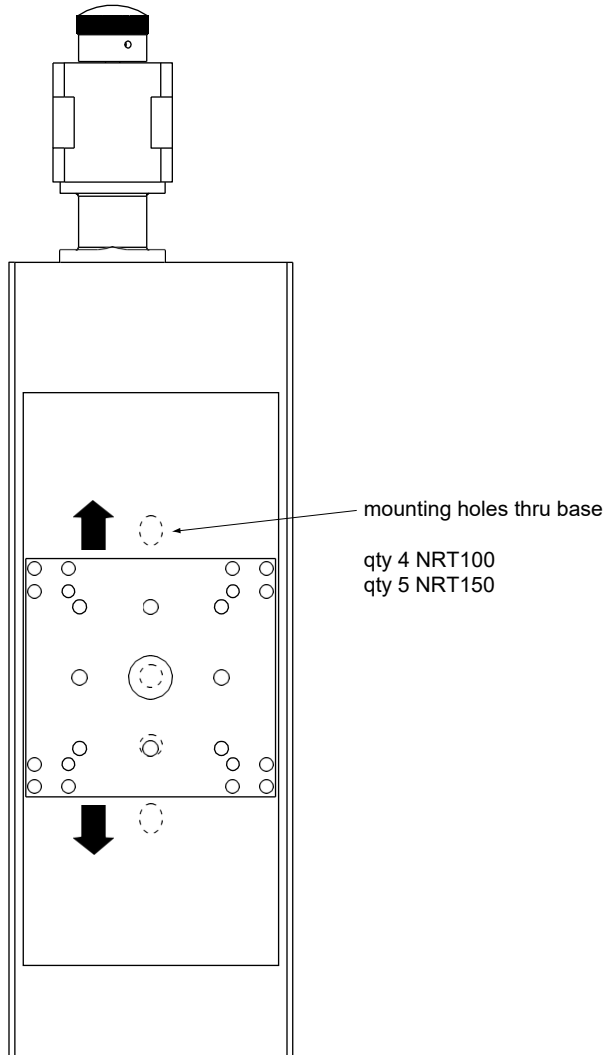

Fig. 3.1 Mounting Holes

3.2.2 Mounting stages in X-Y configurations

Tools required:

5mm hexagon key,

Qty 2, M6 x 12 (1/4-20 UNC x 1/2") cap head bolts,

Engineers square and a flat plate.

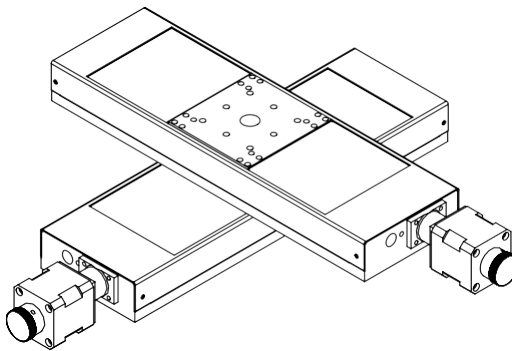
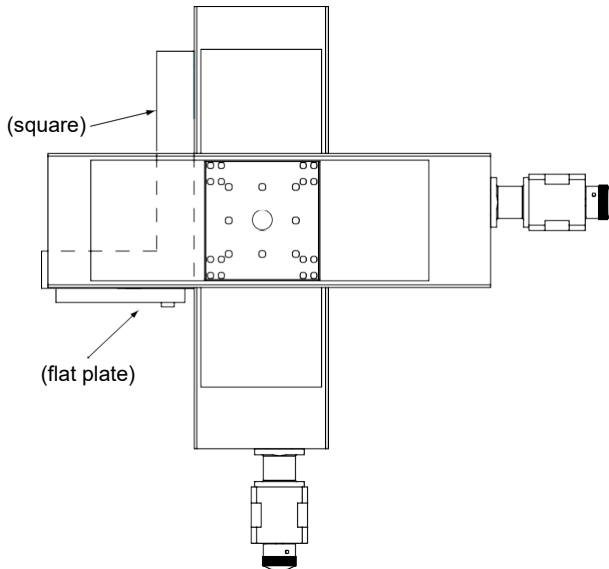

Fig. 3.2 X-Y configuration

- 1) Fix the X axis stage to the worksurface, as detailed in Section 3.2.1.
- 2) Turn the motor knob of the Y axis stage to move the top platform sufficiently to gain access to the fixing holes in the base plate.
- 3) Position the stages as shown in Fig. 3.2.
- 4) Fit and tighten the securing bolts then loosen 1/4 to 1/2 turn.



Caution

Ensure that the screws do not foul the carriage as it moves backwards and forwards.

- 5) If all fixing holes cannot be accessed, move the top platform as necessary to gain access, then repeat items 2) to 5).
- 6) Position the engineers square and flat plate as shown in Fig. 3.2.
- 7) Align the stages squarely then tighten the securing bolts.
- 8) Recheck that the stages are square and readjust as necessary.

3.2.3 Mounting stages in X-Y-Z configurations

- 1) Fix the X axis stage to the worksurface as detailed in Section 3.2.1.
- 2) Assemble two stages in an XY configuration as detailed in Section 3.2.2.
- 3) Fit the Z-bracket assembly (NRT150P1) to the Y axis stage and attach the Z axis stage as shown in Fig. 3.3.

If accurately square z-axis travel is required, use an engineering square to align the orthogonality of the z-axis travel by noting the size of the gap between the moving plate and the square at either end of vertical travel. If there is a noticeable difference in the size of this gap then adjustments should be made through loosening/tightening of the mounting bracket to the stage:

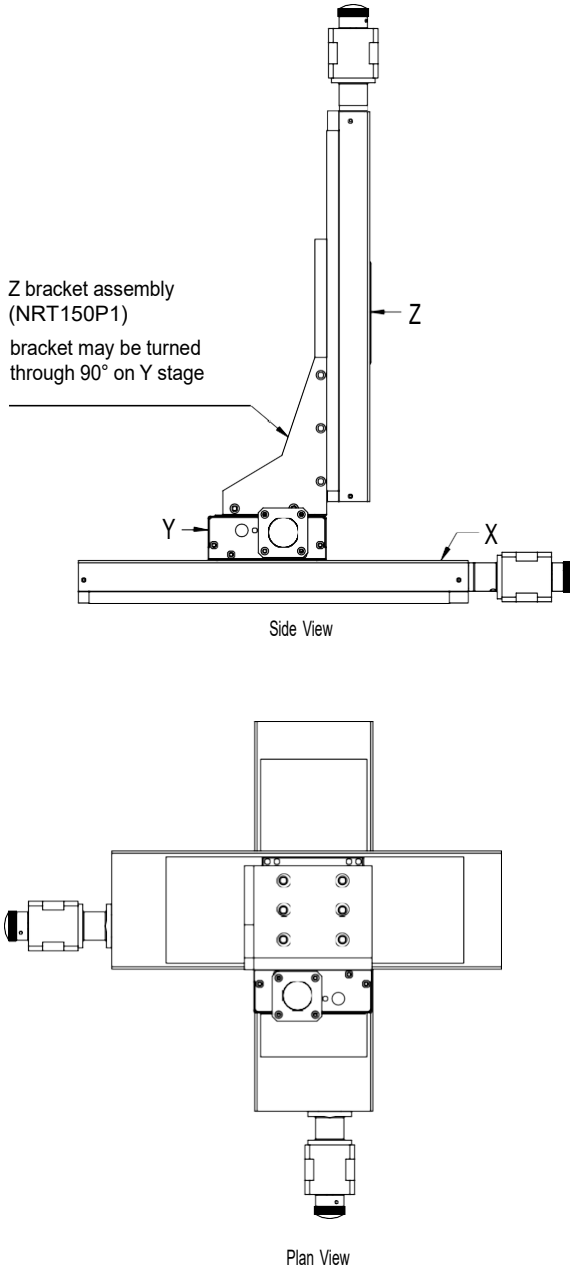

Fig. 3.3 X-Y-Z configuration

3.3 Operation

The NRT stage should be driven by the Thorlabs stepper motor BSC series controllers - see www.thorlabs.com for further details. The flying lead of the stage is terminated in a D-type connector - see Chapter 4 for pin out details, and should be connected to the controller via the extension cable supplied.



Caution

Do not attempt to control this stage using the KST101 or TST101 K-Cube or T-Cube controllers. There is no software configuration for use with these devices.

The stepper motor controller must be switched OFF before the stages are plugged in or unplugged. Failure to switch the controller off may result in damage to either the controller, the stage, or both.

Because it can be software controlled, it should be noted that this device could begin to move unexpectedly for a person within its envelope of operation, who had not programmed the move. However, max speed and load are such that risks are minimal.

3.3.1 System Setup

- 1) Install the electronic hardware and connect the controller to the relevant axes of the associated stage(s) (see the handbooks supplied with the APT Controllers).
- 2) For each Stepper Motor Controller in your system, fit the interlock plug (supplied) to the MOTOR CONTROL connector on the rear panel.

3.3.2 Selecting the Stage Type

To ensure that a particular stage is driven properly by the system, a number of parameters must first be set. These parameters relate to the physical characteristics of the stage being driven (e.g. min and max positions, leadscrew pitch, homing direction etc.).

To assist in setting these parameters correctly, it is possible to associate a specific stage type and axis with the motor controller channel. Once this association has been made, the server automatically applies suitable default parameter values on boot up of the software.

Using APT Software

- 1) Shut down all applications using the APT server (e.g. APT User or your own custom application).
- 2) Run the APT Config utility - Start/All Programs/Thorlabs/APT Config/APT Config.
- 3) From the 'APT Configuration Utility' window, click the 'Stage' tab.

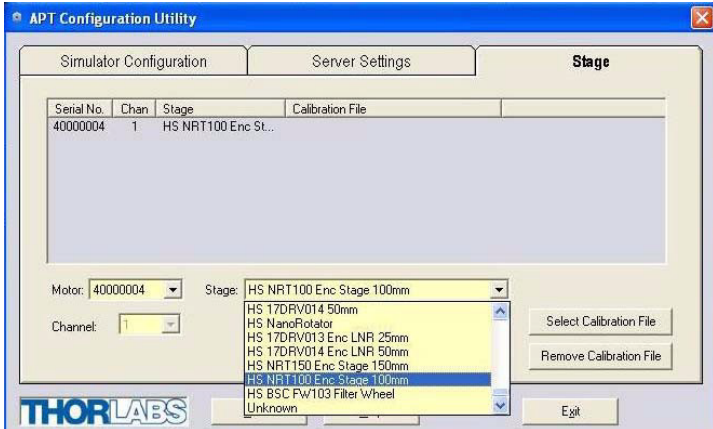

Fig. 3.4 APT Configuration Utility - Stage Tab

- 4) In the 'Motor' field, select the serial number of the stepper motor controller to be configured (this number can be found on the rear panel of the controller unit).

Note

To ensure correct operation, it is important to select the correct stage type for your controller. If using a MST602 or BSC20x series controller, select the appropriate 'HS NRT xxx Enc' option. If using a legacy BSC0xx or BSC10x controller, choose an option without the 'HS' prefix.

Selecting an incompatible stage type could result in reduced velocity and resolution or, when using a joystick, the joystick may be inoperable.

- 5) In the 'Stage' field, select the stage (e.g. 'HS NRT100 Enc') from the list displayed.
- 6) Click the 'Add Stage Association' button.
- 7) A default configuration is set at the factory and stored in the non-volatile memory of the motor controller. The server reads in the stage and controller information on start up.
See the handbook for the associated stepper motor controller for more information on driving the actuator/stage.

Using Kinesis Software

- 1) Ensure that the device is connected to the PC and powered up.
- 2) Run the Kinesis software - Start/All Programs/Thorlabs/Kinesis/Kinesis.
- 3) On start-up, the 'Actuator/Startup Settings' window is displayed. This window allows the correct actuator to be selected.

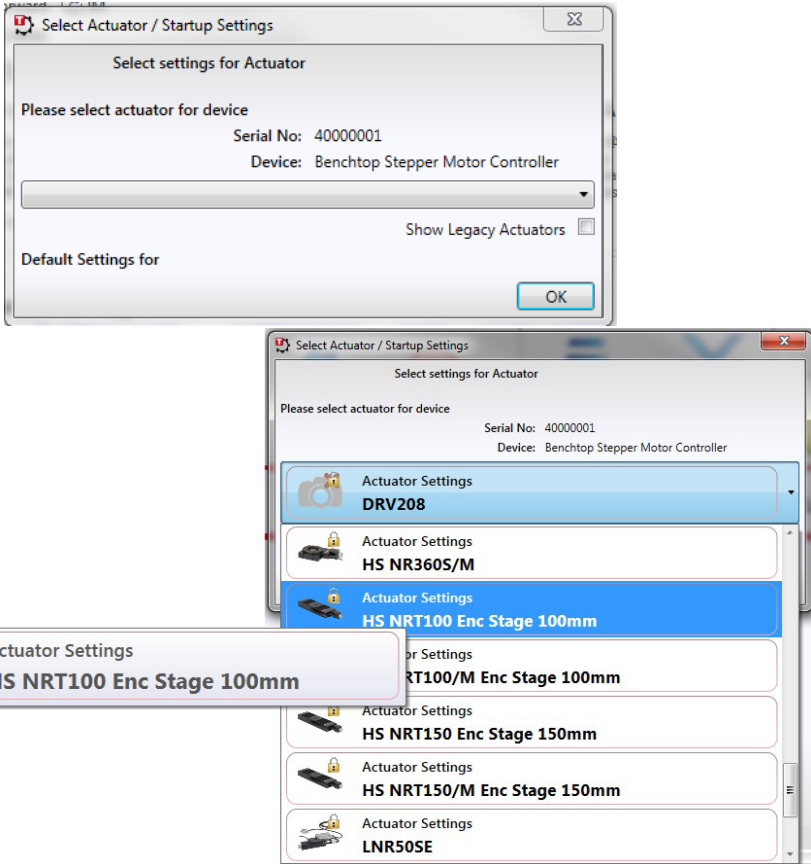

Fig. 3.5 Stage Configuration Window

- 4) From the drop down menu, select your NRT stage type (e.g. HS NRT100 Enc Stage 100mm).
- 5) Click OK.
- 6) The server reads in the stage and controller information automatically. See the handbook for the associated stepper motor controller for more information on driving the actuator/stage.

3.4 Calibration of Motor Drives

Calibration enables the server to correct for any mechanical errors inherent in the system. Mechanical components, such as the leadscrew and linkages, can be machined only within a certain tolerance, e.g. the leadscrew may be nominally 1mm but actually 1.0005 mm, giving a 0.5 micron error. In practice, these errors accumulate from a number of sources, however they are repeatable and therefore, can be compensated.

During calibration, the total positional error is measured at a large number of points and these errors are stored as a look up table (LUT). The LUT is saved as a calibration file, one file for each axis on a particular stage. These files are then linked to the appropriate axis as part of the Stage association process performed using the APT Config utility. Whenever the stage is moved, the LUT is consulted to ascertain the precise movement required to achieve the demanded position.

The use of a calibration file is optional. Without it, the repeatability and resolution of the stage are unaffected, but no compensations are made to enhance the accuracy.

Calibration files can be downloaded from the support documents section on the product web page, one file for each serial number. Details on assigning a calibration file are contained in the *APTConfig On Line Helpfile*.

3.5 Maintenance

The unit contains no user serviceable parts and must be returned to the manufacturer for service and/or repair.



Caution

When packing the unit for shipping, use the original packing. If this is not available, use a strong box and surround the unit with at least 100 mm of shock absorbent material.

Chapter 4 Specification

4.1 Specification

Specification	NRT100(/M)	NRT150(/M)
Travel Range	100 mm (3.9")	150 mm (5.9")
Load Capacity (max)	20 kg (44 lbs) Horizontal 5.0 kg (11 lbs) Vertical	
Bidirectional Repeatability	1.0 μm	
Velocity Range*	40.0 $\mu\text{m/s}$ to 30 mm/s	
Acceleration	30 mm/s ²	
Min Step Size	0.1 μm	
Min Repeatable Incremental Movement	2.0 μm	
On-Axis Accuracy After Calibration	2.0 μm (Typical), 5.0 μm (Max)	
Pitch	0.008° (140 μrad)	
Yaw	0.05° (873 μrad)	
Operating Temperature	+5°C to +40°C	
Weight	2.2 kg (4.8 lbs)	2.5 kg (5.5 lbs)
Construction	Aluminum with precision, recirculating linear bearings	
Full Step Angle	1.8°	
Step Angle Accuracy	5%	
Rated Phase Current	1 A	
Phase Resistance	4.6 Ω	
Phase Inductance	10.6 mH	
Holding Torque	23.1 N•cm	
Detent Torque	1.7 N•cm	
Rotor Inertia	32 g•cm ²	
Insulation	Class B	
Limit Switches	Ceramic-Tipped Mechanical	
Microsteps per Revolution of Leadscrew	409,600	
Motor Type	2-Phase Stepper	
Compatible Controllers	BSC201, MST602	

* The velocity quoted above is only achievable with light loads. When using heavy loads, the velocity should be reduced accordingly.

4.2 Pin Out

The 'Motor' connector provides connection to the stepper motor controller. The pin functions are detailed in Fig. 4.1.

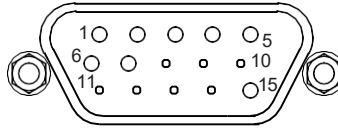

Pin	Description	Pin	Description
1	Limit Switch Ground	9	
2	Forward Limit Switch	10	
3	Reverse Limit Switch	11	
4	Phase B -ve	12	
5	Phase B +ve	13	Limit Switch 5V
6	Phase A -ve	14	
7	Phase A +ve	15	Ground
8			

Fig. 4.1 Motor Connector Pin Descriptions

4.3 Parts List

A 3m cable (PAA613) is included with the stage. The following parts are offered as additional accessories and are available separately.

Part Number	Description
PAA612	Connection Cable 1 m (3.3')
PAA613	Connection Cable 3 m (9.8')
NRT100 and NRT100/M	NanoStep NRT stage with 100mm travel
NRT150 and NRT150/M	NanoStep NRT stage with 150mm travel
NRT150P1	'Z' bracket for fixing stages in X-Z, Y-Z and X-Y-Z configurations
ha0136T	Handbook

Chapter 5 Regulatory

5.1 Declarations Of Conformity

5.1.1 For Customers in Europe



See Section 5.2.

5.1.2 For Customers In The USA

This equipment has been tested and found to comply with the limits for a Class A digital device, pursuant to part 15 of the FCC rules. These limits are designed to provide reasonable protection against harmful interference when the equipment is operated in a commercial environment. This equipment generates, uses and can radiate radio frequency energy and, if not installed and used in accordance with the instruction manual, may cause harmful interference to radio communications. Operation of this equipment in a residential area is likely to cause harmful interference in which case the user will be required to correct the interference at his own expense.

Changes or modifications not expressly approved by the company could void the user's authority to operate the equipment.

5.2 CE Certificate

		<h1>THORLABS</h1>	
		www.thorlabs.com	
<h2>EU Declaration of Conformity</h2> <p><i>in accordance with EN ISO 17050-1:2010</i></p>			
We	Thorlabs Ltd.		
Of	1 Saint Thomas Place, Ely, Cambridgeshire, CB7 4EX		
in accordance with the following Directive(s):			
2006/42/EC	Machinery Directive (MD)		
2004/108/EC	Electromagnetic Compatibility (EMC)		
2011/65/EU	Restriction of Use of Certain Hazardous Substances (RoHS)		
hereby declare that:			
	Model: NRT100 and NRT100/M		
	Equipment: 100mm Motorized Linear Translation Stage (Imperial and Metric)		
is in conformity with the applicable requirements of the following documents:			
EN ISO 12100	Safety of Machinery. General Principles for Design. Risk Assessment and Risk Reduction	2010	
EN61326-1	Electrical Equipment for Measurement, Control and Laboratory Use - EMC Requirements	2006	
and which is in conformity with Directive 2011/65/EU of the European Parliament and of the Council of 8th June 2011 on the restriction of the use of certain hazardous substances in electrical and electronic equipment, for the reason stated below:			
A	does not contain substances in excess of the maximum concentration values tolerated by weight in homogenous materials as listed in Annex II of the Directive		
I hereby declare that the equipment named has been designed to comply with the relevant sections of the above referenced specifications, and complies with all applicable Essential Requirements of the Directives.			
Signed:		On:	03 March 2014
Name:	Keith Dhese		
Position:	General Manager	EDC - NRT100 and NRT100/M -2014	



EU Declaration of Conformity

in accordance with EN ISO 17050-1:2010

We: Thorlabs Ltd.
Of: 1 St. Thomas Place, Ely, CB7 4EX, United Kingdom

in accordance with the following Directive(s):

2006/42/EC	Machinery Directive (MD)
2014/30/EU	Electromagnetic Compatibility (EMC) Directive
2011/65/EU	Restriction of Use of Certain Hazardous Substances (RoHS)

hereby declare that:

Model: **NRT Series**

Equipment: **100 & 150mm Motorized Linear Translation Stage (Imperial and Metric)**

is in conformity with the applicable requirements of the following documents:

EN ISO 12100	Safety of Machinery. General Principles for Design. Risk Assessment and Risk Reduction	2010
EN 61326-1	Electrical Equipment for Measurement, Control and Laboratory Use - EMC Requirements	2013

and which, issued under the sole responsibility of Thorlabs, is in conformity with Directive 2011/65/EU of the European Parliament and of the Council of 8th June 2011 on the restriction of the use of certain hazardous substances in electrical and electronic equipment, for the reason stated below:

does not contain substances in excess of the maximum concentration values tolerated by weight in homogenous materials as listed in Annex II of the Directive

I hereby declare that the equipment named has been designed to comply with the relevant sections of the above referenced specifications, and complies with all applicable Essential Requirements of the Directives.

Signed:  On: 11 February 2019

Name: Keith Dhese

Position: General Manager

EDC - NRT Series -2019-02-11



Chapter 6 Thorlabs Worldwide Contacts



USA, Canada, and South America

Thorlabs, Inc.
sales@thorlabs.com
techsupport@thorlabs.com

Europe

Thorlabs GmbH
europe@thorlabs.com

France

Thorlabs SAS
sales.fr@thorlabs.com

Japan

Thorlabs Japan, Inc.
sales@thorlabs.jp

UK and Ireland

Thorlabs Ltd.
sales.uk@thorlabs.com
techsupport.uk@thorlabs.com

Scandinavia

Thorlabs Sweden AB
scandinavia@thorlabs.com

Brazil

Thorlabs Vendas de Fotônicos Ltda.
brasil@thorlabs.com

China

Thorlabs China
chinasales@thorlabs.com

Thorlabs verifies our compliance with the WEEE (Waste Electrical and Electronic Equipment) directive of the European Community and the corresponding national laws. Accordingly, all end users in the EC may return "end of life" Annex I category electrical and electronic equipment sold after August 13, 2005 to Thorlabs, without incurring disposal charges. Eligible units are marked with the crossed out "wheelie bin" logo (see right), were sold to and are currently owned by a company or institute within the EC, and are not disassembled or contaminated. Contact Thorlabs for more information. Waste treatment is your own responsibility. "End of life" units must be returned to Thorlabs or handed to a company specializing in waste recovery. Do not dispose of the unit in a litter bin or at a public waste disposal site.



UNLEASHED



THORLABS
www.thorlabs.com
