



OSL1, OSL1-EC

High Intensity Fiber Light Source

Operating Manual



Table of Contents

| | | |
|----------------|---|-----------|
| Part 1. | Warnings..... | 4 |
| | 1.1. Precautions | 4 |
| | On Power Sources..... | 4 |
| | On Operation | 5 |
| | On Cleaning | 5 |
| Part 2. | Getting Started | 6 |
| | Unpacking – OSL1 and OSL1-EC | 6 |
| | Hookup Overview | 6 |
| | Before You Get Started..... | 6 |
| Part 3. | Description..... | 7 |
| | Front Panel Light Source Descriptions | 7 |
| | Rear Panel Light Source Descriptions..... | 7 |
| Part 4. | Lamp Replacement | 8 |
| | Lamp Replacement Instructions..... | 8 |
| Part 5. | Specifications | 9 |
| | Dimensional Drawing | 9 |
| Part 6. | Regulatory | 10 |
| Part 7. | Thorlabs Worldwide Contacts..... | 11 |

Table of Figures

| | |
|---|---|
| Figure 1: Front Panel Description | 7 |
| Figure 2: Rear Panel Description | 7 |
| Figure 3: Lamp Access Diagram | 8 |
| Figure 4: Dimensional Drawing | 9 |

Part 1. Warnings

| Caution | |
|--|-------------------------|
| RISK OF ELECTRIC SHOCK. DO NOT OPEN | |
| INPUT: 180 W, Max | |
| <u>Line</u> | <u>Fuse, 5 x 20 mm</u> |
| 99 – 121 VACX, 60 Hz | 3 A Quick Acting |
| 200 – 244 VAC, 50 Hz | 2 A Quick Acting |



This symbol is intended to alert the user to the presence of important operating and maintenance (servicing) instructions to the literature accompanying the appliance.



This symbol is intended to alert the user to the presence of uninsulated “dangerous voltage” within the product’s enclosure that may be of sufficient magnitude to constitute a risk of electric shock to persons.

Important

This equipment has been tested and found to comply with IEC 61010-1 and UL3101-1 as an Overvoltage Category II: (local level, small appliances, portable equipment, etc. with smaller transient over voltages than Overvoltage Category III.) Pollution II.

Caution

You are cautioned that any change or modifications not expressly approved in this manual could void your authority to operate this equipment.

1.1. Precautions

On Power Sources

- Before operating the product, check that the operating voltage is identical to your local power supply. See specific descriptions for operating voltages.
- This unit is not disconnected from the AC power source as long as it is connected to the wall outlet, even if the unit itself has been turned off.
- To disconnect the AC power cord, grasp the plug itself; never pull the cord.
- One blade of the plug is wider than the other for the purpose of safety and will fit into the wall outlet only one way. If you are unable to fully insert the plug into the outlet, please contact your local Thorlabs tech support.
- AC power cord must be replaced with IEC compatible cord.

On Operation

Before connecting to fiber optic components, be sure that all power connections are secure.

On Cleaning

Clean the cabinet, panel, and controls with a soft cloth slightly moistened with a mild detergent solution. Do not use any type of abrasive pad, scouring powder or solvent such as alcohol or benzine.

Part 2. Getting Started

Unpacking – OSL1 and OSL1-EC

Check that you received all items on the packing list.

Hookup Overview

The OSL1 High Intensity Fiber Light Source allows the user to connect and control a variety of fiber optic components. To learn the locations and names of important connections see “Illuminator Descriptions” below.

Before You Get Started

- Turn off the power to the OSL1 before making any connections.
- Do not connect the AC power cord to the local power supply until the connections are completed to the OSL1.
- Be sure to make connections firmly.
- Be sure that the OSL1 and OSL1-EC operating voltage matches the “local” power supply.

Part 3. Description

Front Panel Light Source Descriptions

1. Variable intensity controller (0 to 100%).
2. On/Off rocker switch.
3. Front panel fasteners (2)
4. Lamp module.
5. V-port with T-handle retainer

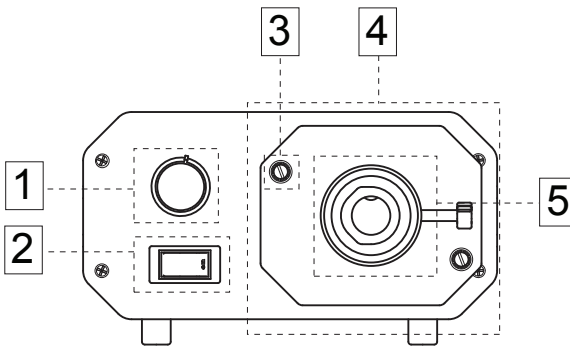

Figure 1: Front Panel Description

Rear Panel Light Source Descriptions

1. T-slot mounting for #1/4 - 20 or M6 hexhead fastener; both sides (#10 - 32 or M5 barnut optional)
2. IEC inlet with line filtering (power cable input)
3. Operating voltage label

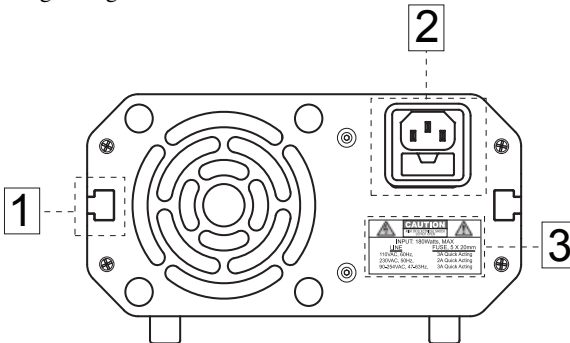

Figure 2: Rear Panel Description

Part 4. Lamp Replacement

Lamp Replacement Instructions

1. To replace the lamp, shut off the power and remove the power cord from the AC outlet. To disconnect the AC power cord, grasp the plug itself; never pull the cord.
2. Located on the lamp access panel, manually loosen the front panel fasteners.
3. With front panel released, remove the lamp module from the unit. Use caution; fan blades are accessible while lamp module is removed.
4. Allow sufficient time for the unit to cool. **CAUTION:** Lamp and surfaces may be extremely hot!
5. Remove the lamp from the socket and place in a safe area.
6. Insert the replacement lamp into the socket; pressing firmly to ensure that pins are fully seated.
7. Close the access panel.
8. Secure the lamp access panel by manually tightening the front panel fasteners.

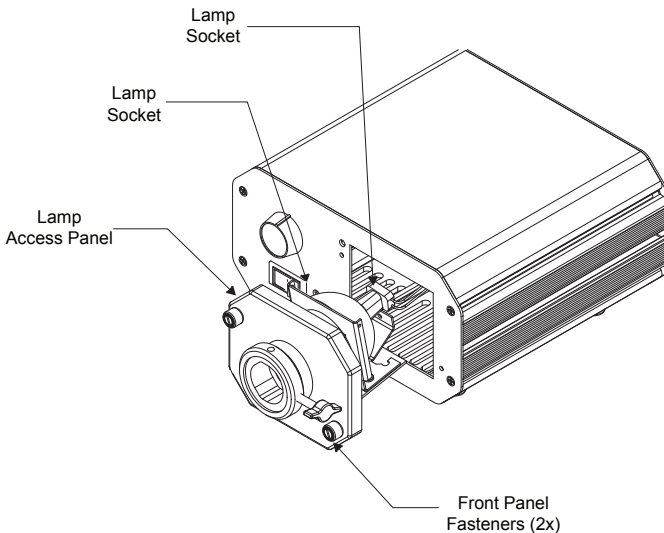

Figure 3: Lamp Access Diagram

On Safety

Should any solid object or liquid fall into the assembly while access panel is open, have it checked by qualified personnel before operating.

Part 5. Specifications

| Item # | OSL1 | OSL1-EC |
|-------------------------------|--|---------|
| Environmental | | |
| Operating Temperature | -4 to 104°F (-20° to 40°C) | |
| Humidity Range | 0 to 80%; non-condensing | |
| Pollution Degree | 2 | |
| Electrical (all units) | | |
| Operating Frequency | 60 Hz (110 VAC) or 50 Hz (220VAC) | |
| Power Consumption | 180 W at Full Light Intensity | |
| Power Requirements | 110 VAC; 60 Hz 220 VAC; 50 Hz | |
| Lamp Adjustment Range | 0 to 100% | |
| Color Temperature | 3200 K at Max Intensity (assuming standard EKE lamp) | |
| Lamp Life | 250 to 10,000 hours | |
| Physical | | |
| Mass | 4.5 lbs. (2.04 kg) approx. | |
| Lamp Type | 150W EKE, 3250K (#20094145)* 150W EKE-HC, 4200K (#20094142) 150W EJV, 3400K (20094143) | |
| Fuse Type | 3.15 A, 250 V, 5 x 20 mm | |

* Standard lamp type provided with illuminator.

Dimensional Drawing

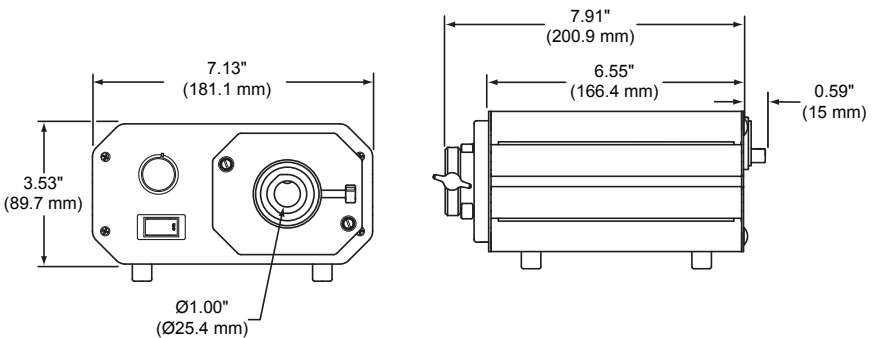

Figure 4: Dimensional Drawing

Part 6. Regulatory

As required by the WEEE (Waste Electrical and Electronic Equipment Directive) of the European Community and the corresponding national laws, Thorlabs offers all end users in the EC the possibility to return “end of life” units without incurring disposal charges.

- This offer is valid for Thorlabs electrical and electronic equipment:
- Sold after August 13, 2005
- Marked correspondingly with the crossed out “wheelie bin” logo (see right)
- Sold to a company or institute within the EC
- Currently owned by a company or institute within the EC
- Still complete, not disassembled and not contaminated



Wheelie Bin Logo

As the WEEE directive applies to self contained operational electrical and electronic products, this end of life take back service does not refer to other Thorlabs products, such as:

- Pure OEM products, that means assemblies to be built into a unit by the user (e.g. OEM laser driver cards)
- Components
- Mechanics and optics
- Left over parts of units disassembled by the user (PCB's, housings etc.).

If you wish to return a Thorlabs unit for waste recovery, please contact Thorlabs or your nearest dealer for further information.

6.1. Waste Treatment is Your Own Responsibility

If you do not return an “end of life” unit to Thorlabs, you must hand it to a company specialized in waste recovery. Do not dispose of the unit in a litter bin or at a public waste disposal site.

6.2. Ecological Background

It is well known that WEEE pollutes the environment by releasing toxic products during decomposition. The aim of the European RoHS directive is to reduce the content of toxic substances in electronic products in the future.

The intent of the WEEE directive is to enforce the recycling of WEEE. A controlled recycling of end of live products will thereby avoid negative impacts on the environment.

Part 7. Thorlabs Worldwide Contacts

For technical support or sales inquiries, please visit us at www.thorlabs.com/contact for our most up-to-date contact information.



USA, Canada, and South America

Thorlabs, Inc.
sales@thorlabs.com
techsupport@thorlabs.com

Europe

Thorlabs GmbH
europe@thorlabs.com

France

Thorlabs SAS
sales.fr@thorlabs.com

Japan

Thorlabs Japan, Inc.
sales@thorlabs.jp

UK and Ireland

Thorlabs Ltd.
sales.uk@thorlabs.com
techsupport.uk@thorlabs.com

Scandinavia

Thorlabs Sweden AB
scandinavia@thorlabs.com

Brazil

Thorlabs Vendas de Fotônicos Ltda.
brasil@thorlabs.com

China

Thorlabs China
chinasales@thorlabs.com



THORLABS

www.thorlabs.com
