

CLEARANCE BORE FOR USE WITH 1/4in [M6] CAP SCREW
4 PLACES

Ø 2.00in [50.8mm]

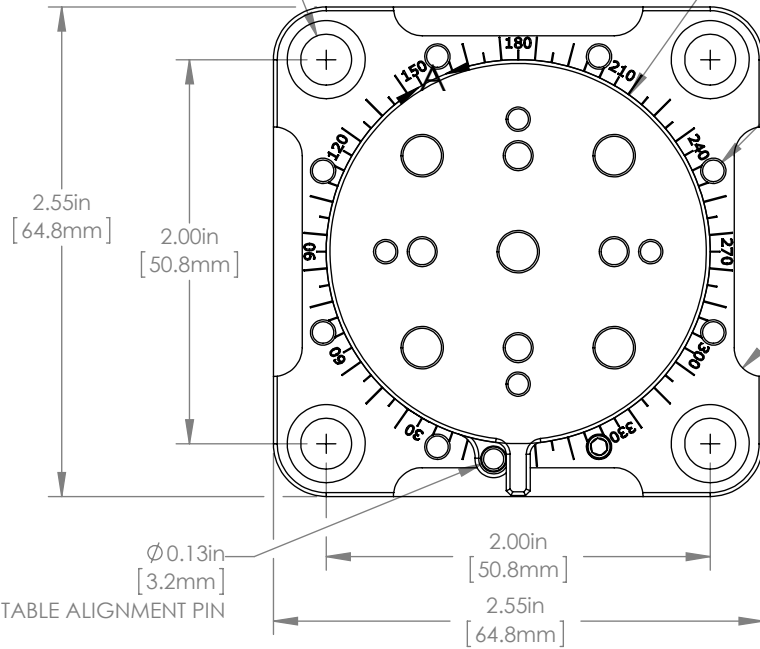

4-40 THREADED HOLE FOR USE WITH THREADED ALIGNMENT PIN
8 PLACES

RELIEF CUT FOR USE WITH CL8 AND CL6 TABLE CLAMPS
4 PLACES

Ø 0.13in [3.2mm]
ADJUSTABLE ALIGNMENT PIN

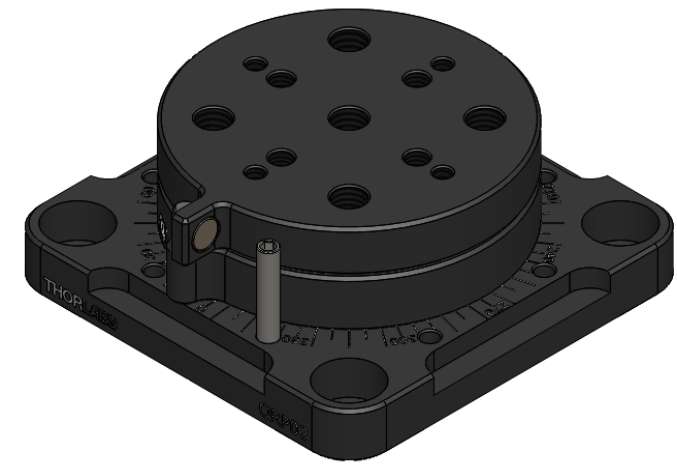

8-32 THREAD
0.18in [4.6mm] DEEP
4 PLACES

6-32 THREAD
0.20in [5.1mm] DEEP
4 PLACES

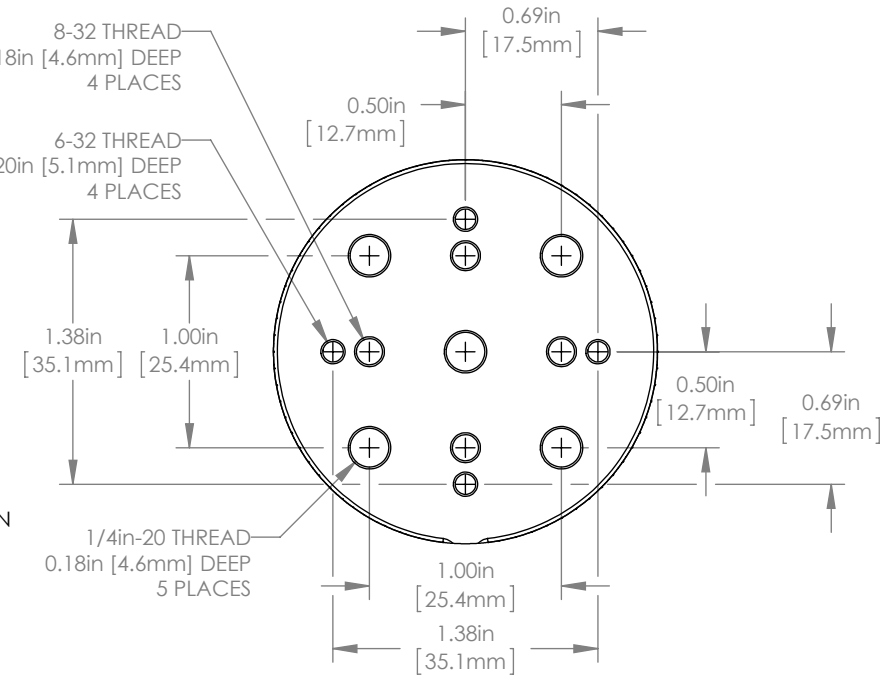

TOP PLATFORM

MAGNETIC TAB USED FOR ROTATION AND POSITIONING AGAINST ALIGNMENT PINS

Ø 1/8in REMOVABLE ALIGNMENT PIN
5/64in [2mm] HEX

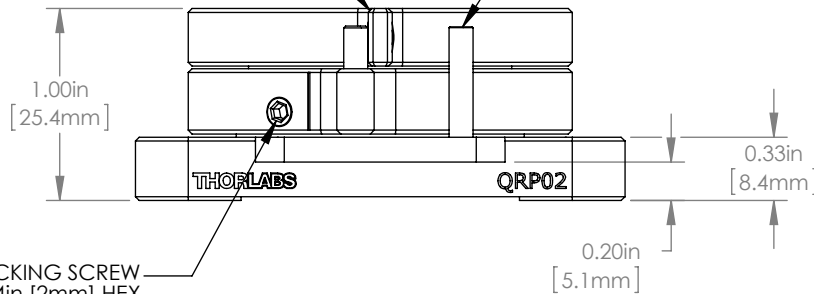

CENTRAL PLATE LOCKING SCREW
5/64in [2mm] HEX

FOR INFORMATION ONLY
NOT FOR MANUFACTURING PURPOSES

DRAWING PROJECTION



	NAME	DATE
DRAWN	PG	14/MAY/13
APPROVAL	HP	15/MAY/13

COPYRIGHT © 2013 BY THORLABS

VALUES IN PARENTHESIS ARE CALCULATED AND MAY CONTAIN ROUND OFF ERRORS

THORLABS
www.thorlabs.com

QUICK ROTATION PLATFORM

MATERIAL N/A REV A

ITEM # QRP02 APPROX WEIGHT 0.17 kg