THORLABS

SHB05 and SHB05T 0.5" High Speed Shutters and Controller

User Guide



















Table of Contents

Chapter 1	Warning Symbol Definitions	3
Chapter 2	Safety.....	4
Chapter 3	Description.....	5
	3.1. Overview	6
Chapter 4	Setup and Operation	8
	4.1. Connection Guide.....	8
	4.2. Manual Shutter Operation	8
	4.3. External Modulation Modes.....	9
	4.3.1. Protected Mode	10
	4.3.2. Unprotected Mode	10
	4.4. Default to On	11
	4.5. Interlock Output.....	11
	4.6. Indicators.....	12
	4.6.1. Power LED.....	12
	4.6.2. Status LED.....	12
	4.7. Timing Performance.....	13
	4.8. Typical Performance	14
	4.9. SHB05T Coating Performance.....	14
Chapter 5	Specifications	15
Chapter 6	Interface Connector	16
Chapter 7	Cleaning and Maintenance	17
Chapter 8	Troubleshooting	18
Chapter 9	Mechanical Drawing.....	19
Chapter 10	Declaration of Conformity	20
Chapter 11	Regulatory.....	21
Chapter 12	Thorlabs Worldwide Contacts.....	22

Chapter 1 Warning Symbol Definitions

Below is a list of warning symbols you may encounter in this manual or on your device.

Symbol	Description
	Direct Current
	Alternating Current
	Both Direct and Alternating Current
	Earth Ground Terminal
	Protective Conductor Terminal
	Frame or Chassis Terminal
	Equipotentiality
	On (Supply)
	Off (Supply)
	In Position of a Bi-Stable Push Control
	Out Position of a Bi-Stable Push Control
	Caution: Risk of Electric Shock
	Caution: Hot Surface
	Caution: Risk of Danger
	Warning: Laser Radiation
	Caution: Spinning Blades May Cause Harm

Chapter 2 Safety

All statements regarding safety of operation and technical data in this instruction manual will only apply when the unit is operated correctly.

The unit is supplied with line cord with a North American or European plug. Make sure your line cord fits your local outlets. The unit is equipped with an external switching power supply for voltages from 100 to 240 VAC. There is no need to change the fuse when selecting your regional mains voltage. There are no user serviceable parts in this product.



CAUTION



The SHB05(T) shutters can exceed temperatures of 70 degrees Celsius when operated outside of heat-sinking mounts, which can burn the skin. For safety, allow approximately 5 minutes of cool down after operation before handling.



CAUTION



DO NOT OPEN HOUSING! The SHB05(T) shutters and controller have no user-serviceable parts. Do not operate without cover installed.



WARNING



Do not operate in wet or damp conditions.



WARNING



Mobile telephones, cellular phones, or other radio transmitters should not be used within the range of three meters of this unit since the electromagnetic field intensity may exceed the maximum allowed disturbance values according to EN50082-1.



WARNING



Space the front side of the shutter head at least 1/8" from ferrous materials. Keep shutter head away from strong magnetic fields. Both may interfere with shutter operation.



WARNING



In the event of a power failure the shutter will not close.

Chapter 3 Description

The SHB05 and SHB05T are one-half-inch-aperture, high-speed, bladed shutters, driven by the included shutter controller. The shutter connects to the controller through a shielded four-conductor cable using a four-pin, mini-DIN connector. The included controller provides the drive levels required for optimal performance and monitors the state of the shutter. The controller has a BNC connector for external modulation, and an interlock output jack for safety. A switching power supply is included.

The SHB05(T) can be controlled directly from the buttons on the controller or via an external modulation source. There are two buttons on top of the controller unit, one to turn the power on and off and the other, labeled as ENABLE, to open or close the shutter. When the unit is first powered on, it is in the mode it was last, either Manual or External Modulation Mode expecting input from the external modulation port. Manually depressing the ENABLE button will open and close the shutter. To use the modulation input, press and hold the ENABLE button for 3 seconds.

The external modulation port can drive the shutter up to a maximum frequency of 25 Hz. In normal operation, when the logic of the external modulation pulse is high, the shutter will open. When it is low, the shutter will be closed. In normal operation, the shutter will shut down if it is run at its max frequency for too long to prevent overheating. In Unprotected Mode, this safety feature is disabled and the unit may be damaged if run too long without thermal control.

The SHB05(T) has many safety features. The controller detects the state of the shutter using an internal optical sensor inside the shutter package. The optical sensor detects the shutter blade's position, confirming if the shutter is open or closed. This feature, when used with the interlock connector, makes this shutter ideal for applications where a laser safety lockout is required. In the event of a failure such as a blade jam, the SHB05(T) will shut down. This changes the state of the interlock and LED light will turn red. The SHB05(T) can detect when the blades are not operating at the set frequency and will shut down to prevent damage to the SHB05(T).

The SHB05(T) come with the shutter head, controller, external switching supply, AC cord, and this manual.

3.1. Overview

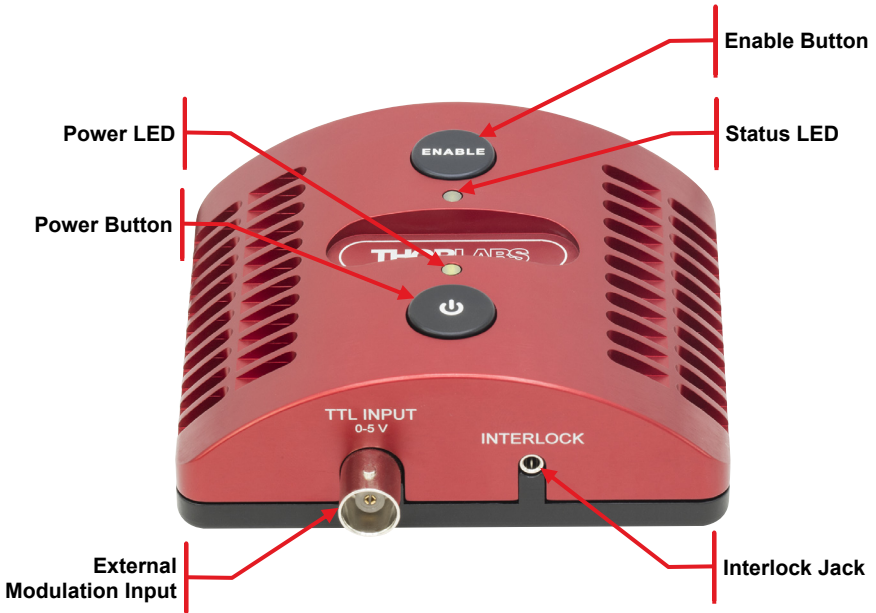

Figure 1 Controller Front View



Figure 2 Controller Rear View

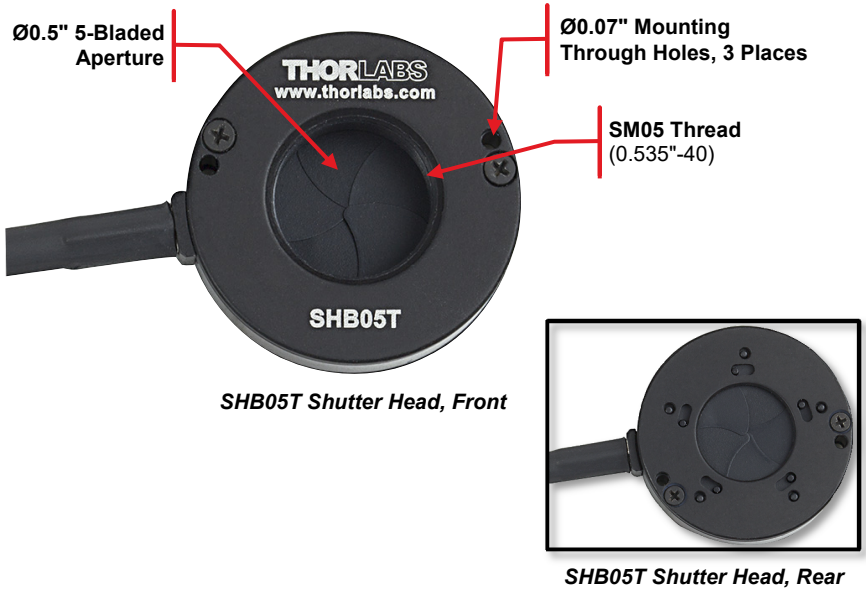
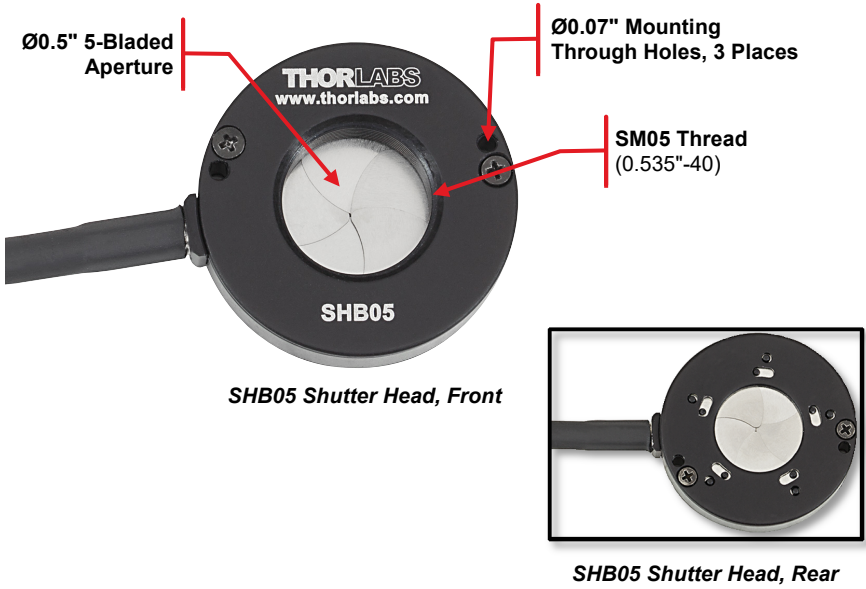

Figure 3 Shutter Head Front and Rear Views

Chapter 4 Setup and Operation

4.1. Connection Guide

1. Remove components from the case.
2. Secure the SHB05(T) shutter head to your setup using the three mounting holes, the SM05 thread, or a mounting adapter (sold separately).
3. Connect the AC power cord to the power supply and then connect to the AC power outlet. The SHB05 and SHB05T are each supplied with an external AC-DC switching power supply rated at 100 – 240 VAC, 47 – 63 Hz, and 5 VDC @ 2.4 A maximum output.
4. Place the controller on a flat surface. Connect the mini-DIN connector from the shutter head, with the arrow on the connector pointing up, into the controller.
5. Turn the unit on by pressing the power button.

4.2. Manual Shutter Operation

There are two LEDs on top of the unit. The LED next to the power button is green when the power is on or off when the power is off. The LED next to the enable button indicates the status of the controller as shown in the table below.

Status LED Color	Meaning
Off	Shutter is Closed
Green	Shutter is Open
Amber	Controller is in Unprotected Mode and Shutter is Open
Red	There is an Error

Note that when the shutter is closed and in unprotected mode, the LED will be off. Additionally, unplugging the shutter from the wall outlet will not change its mode, so if it is in Unprotected Mode and unplugged, it will still be in Unprotected Mode when plugged back in again. See Section 4.3.2 for more information on Unprotected Mode.

The shutter generally defaults to the closed position. The following table outlines the various conditions that will change the shutter's state. For more information on the meaning of the LED colors and modes, please see Section 4.6.2.

Condition	Shutter State	
	Open	Closed
Depressing the ENABLE button	Closes	Opens
Power plugged into either wall outlet or controller	Closes	Stays Closed
Power button depressed to turn on	Closes	Stays Closed
Power button depressed to turn off	Closes	Stays Closed
Unplugging power cord from wall outlet or controller	Stays Open	Stays Closed
Unplugging shutter from controller	Stays Open	Stays Closed
Plugging shutter into controller while it is on	Shutter will revert to whatever state it indicated by the controller, usually no change.	

To manually control the shutter, after powering on the unit, simply press the ENABLE button. This will open the shutter. Depressing the button a second time will close the shutter. If the unit is in an External Modulation Mode, pressing the ENABLE button once will put the device into Manual Mode without opening the shutter and the Status LED will flash four times.

The SHB05(T) is set to the last mode it was in when it is powered on. Pressing the ENABLE button puts it in Manual Mode if it was in Protected or Unprotected External Modulation Mode. This disables the external modulation input connector (the BNC connector port labeled TTL Input on the controller). To return the device to Protected External Modulation Mode, press and hold the ENABLE button for 3 seconds.

The Status LED will flash two times to indicate the device is in Protected External Modulation Mode, and the shutter will start changing state provided there is a TTL signal active on the port.

4.3. External Modulation Modes

CAUTION

Prolonged modulation of these shutters will eventually result in premature component wear and failure. This device is not intended for long-term continuous modulation.

To control the SHB05(T) shutter state using an external, modulated TTL signal, connect the signal source to the shutter controller at the BNC TTL Input connector. Activate the TTL signal source. The shutter will be in the last state it was in when powered on, therefore if it does not begin modulating, press and hold the ENABLE button to enter the Protected External Modulation Mode. The TTL requirements are:

- TTL Level Input Voltage
 - A High Logic state is 2 – 5 V
 - A Low Logic state is 0 – 0.8 V
- At the Modulation Input
 - Logic Level High opens the shutter
 - Logic Level Low closes the shutter

The maximum continuous operating frequency limit is 15 Hz. The unit can operate up to 25 Hz for a limited amount of time. After the time limit is exceeded or the modulation frequency exceeds 25 Hz, the shutter will disable, the Status LED will turn red, and the interlock will open. See Chapter 5 for more information on how long the unit can be run from 16 to 25 Hz.

4.3.1. Protected Mode

When the SHB05(T) operates in Protected Mode, the device will shut down if run for too long over 15 Hz. This is in order to protect the device from overheating. The unit does not monitor the temperature directly, but the time limit is based on calculations assuming no heat control at room temperature. If the user utilizes some kind of heat mitigation system, they may set the unit to Unprotected Mode where the time limit alarm is ignored and the device will operate continuously. Note that operating the shutter in Unprotected Mode may damage the unit.

The following table outlines the length of time the device can be operated safely above 15 Hz.

Protected Mode Specifications	Value
Max Operating Freq. Continuous	15 Hz
Burst Mode (Less than 1 minute)	16 – 25 Hz

4.3.2. Unprotected Mode

The SHB05(T) normally operates in Protected Mode. In this mode, the unit will disable the blades, turn the Status LED red, and trip the interlock when the unit is run over 15 Hz and the time limit is reached (see Chapter 5 for more information). In Unprotected Mode, the unit will not disable under those conditions.

To enter Unprotected Mode, hold both the POWER and ENABLE buttons until the Status LED flashes amber four times. While in Unprotected Mode, the Status LED will remain amber, so any condition that normally would be green will now be amber. To exit Unprotected Mode, depress both buttons until the Status LED flashes green four times. This will put the device back into Protected External Modulation Mode. Pressing the ENABLE button while in Unprotected mode, will exit Unprotected Mode and enter Manual Mode. The LED will turn green.

The table below summarizes the different states and how to enter them.

Current Mode	To Manual Mode	To External Protected Mode	To External Unprotected Mode
Manual	-	Hold Enable button for 3 seconds.	Hold Power and Enable buttons for 3 seconds.
External Protected	Press Enable button.	-	Hold Power and Enable buttons for 3 seconds.
External Unprotected	Press Enable button.	Hold Power and Enable buttons for 3 seconds.	-

4.4. Default to On

The default to on setting allows the SHB05(T) to automatically power ON when DC is applied; for users that require auto power ON when DC is applied without pressing the POWER button. To enter or exit this setting, follow the steps below:

1. Connect the DC power supply.
2. Press and hold the Enable button; then press and hold the Power button simultaneously for (1 second).
3. Both the Power and Enable Led will light.
4. Release both the Power and Enable buttons.
5. The Power and Enable LEDs will remain on for >3 seconds.
6. The controller will now reboot and power on (Power LED on).

Note, when set to Default to On, the POWER button functions normally.

4.5. Interlock Output

An interlock output is provided. In the event of a failure, the interlock circuit will trip and the contacts will open. The interlock uses contacts to represent the state of operation.

The contacts are set NO (Normally Open). If the contacts are NO, the power is OFF and DC is disconnected. In a normal operating condition the contacts will be closed where the feedback monitor does not detect any error.

There are three different error conditions where the contacts would be in an open state. These error conditions would result when:

- The shutter is not changing state with reference to its drive signal, such as a jammed blade.
- An over temperature condition has been detected.
- The maximum drive frequency of 25 Hz is exceeded.

All error conditions result in the Status LED changing to red.

Specification of Interlock Contacts	
Max Operating voltage	12 VDC
Max Current	1 A
Mating Connector	2.5 mm Mono Phono Jack

If you wish to make use of the Interlock feature you will need to acquire the appropriate connector and wire it to your device. The Interlock input only accepts a 2.5 mm mono phono jack. This connector is readily available at most electronics stores.

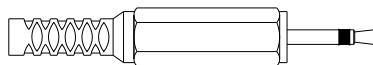

Figure 4 Remote Interlock Connector (Not Included)

4.6. Indicators

4.6.1. Power LED

The Power LED will be lit green when the power is on and dark when the power is off.

4.6.2. Status LED

The table below outlines the color of the Status LED and the meaning depending on the mode. When the Status LED turns red, the device will shut down until the user cycles the power. However, when the device is in Unprotected Mode, the Status LED will still turn amber 15 seconds before an over temperature condition and stay amber when an over temperature condition occurs, but the device will not shut down.

Mode	Shutter Closed	Shutter Open	Over Temp. Warning	Over Temp.	Max Freq Exceeded	Blade Jammed
Manual	●	●	○	○	○	●
External Protected	●	●	● ¹	●	●	●
External Unprotected	●	●	● ²	●	●	●

- LED is green ○ Not applicable in that mode
- LED is amber ● LED is off
- LED is red

¹ LED will turn solid amber 15 seconds prior to shut down. It will no long turn on and off as shutter opens and closes.

² LED will turn solid amber 15 seconds prior to when shut down would occur in protected mode. However, in unprotected mode, unit will not shut down.

4.7. Timing Performance

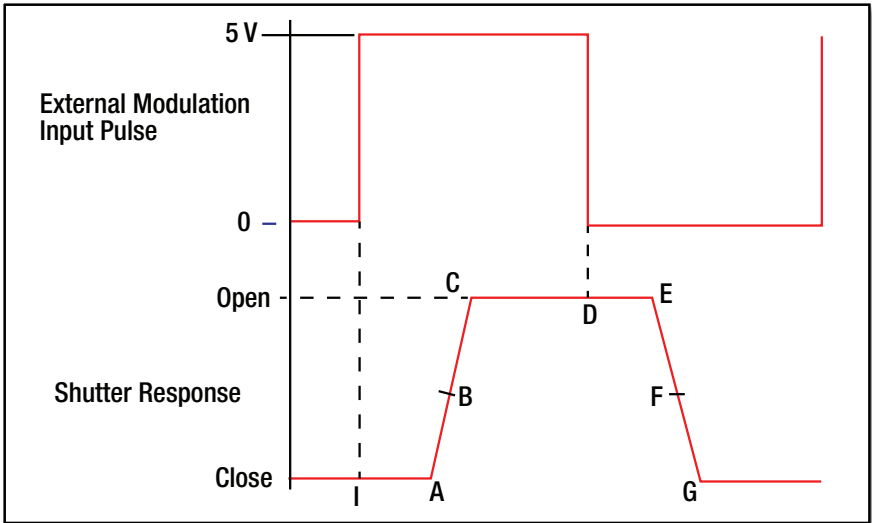

Figure 5 SHB05(T) Timing Driven by SHB05(T) Shutter Controller

	Time (ms, Typ)	Time (ms, Max)	Definitions
I → A	8	10	Delay from input pulse rising edge to initiation of shutter opening.
A → C	8	10	Rising edge to 100% open.
I → C	16	19	Delay from input pulse rising edge to shutter fully opening.
D → E	7	10	Delay from fall of input pulse to initiation of shutter fully closing.
E → G	9	12	Falling edge to 100% closed.
D → G	16	18	Delay from fall of input drive to shutter fully closed.
Minimum Drive Pulse (MDP)			
These measurements use the MDP, which is the minimum pulse to drive the minimum open time (I → D).			
I → D	29	31	Minimum pulse to drive minimum open time.
C → E	21	22	Minimum exposure pulse; @ top of pulse.
B → F	29	31	Minimum exposure pulse; @ 50% of pulse.
A → G	37	40	Minimum exposure pulse; @ bottom of pulse.

4.8. Typical Performance

The time it takes to open the shutter or close the shutter (IA and DE as shown in Figure 5) are constant characteristics of the device. The time delay for both opening and closing is a result of the time it takes to energize the coils.

The net effect is the delay from the initiation of the starting pulse to the shutter responding (IA) is typically 8 ms. Similarly, the closing time (DE) is typically 7 ms.

The mechanical rise time of the shutter is given as AC in Figure 5. The fall time is given as EG. The typical values for the rise and fall times respectively are 8 ms and 9 ms.

Therefore, the total time it typically takes for the shutter to open would be IC or 16 ms. The total time it typically takes for the shutter to close would be DG or 16 ms. Depending on your application, some or all of these values are important to note.

4.9. SHB05T Coating Performance

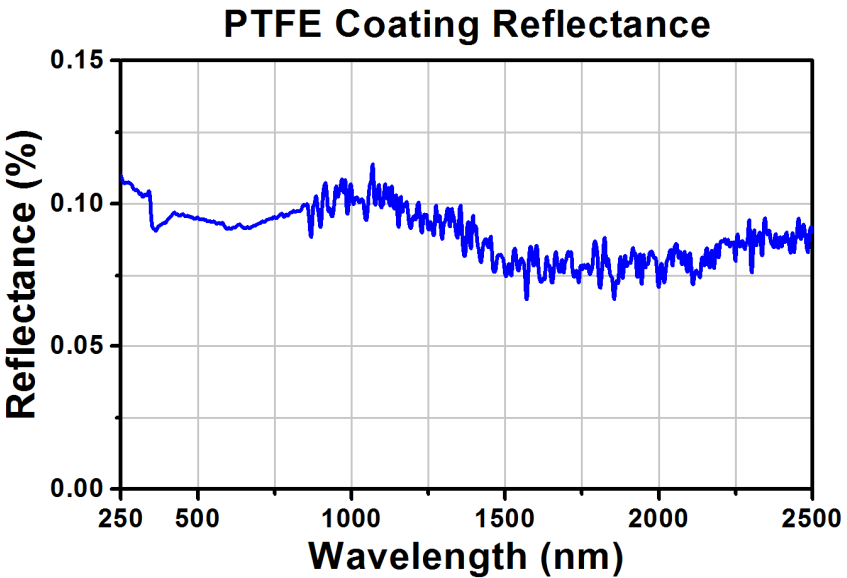

The plot above gives the typical reflectance of the PTFE coating on the blades of the SHB05T. This data is not guaranteed and should be used only as a reference.

Chapter 5 Specifications

All values at 25 °C unless otherwise noted.

Specification	Value
Electrical Specifications (Shutter Mechanism)	
External Modulation Input Voltage, TTL	Low: 0 – 0.8 VDC High: 2.0 – 5.0 VDC
Coil Resistance	8.2 Ω ± 2.5%
Shutter Drive Voltage	7.0 VDC Typ, 8.0 VDC Max
Controller Drive Type	PWM @ 20 KHz
Performance Specifications	
Operating Temperature	15 – 40 °C
Operating Freq. Over Operating Temp Range	0 – 25 Hz
Min Exposure Pulse ³	29 ms Typ, 31 ms Max
Exposure Accuracy ⁴	2 ± 0.5 ms
Exposure Repeatability Jitter ⁵	< 4 ms
Jitter Rising Edge ≤15 Hz	1.8 ms Typical, 4 ms Max
Jitter Falling Edge ≤15 Hz	1.8 ms Typical, 4 ms Max
Jitter Rising Edge 16 – 25 Hz	3.5 ms Typical, 8 ms Max
Jitter Falling Edge 16 – 25 Hz	3.5 ms Typical, 8 ms Max
Rise Time	8 ms Typical, 10 ms Max
Fall Time	9 ms Typical, 12 ms Max
Protected Mode	
Max Operating Freq., Continuous ⁶	15 Hz
Max Operating Freq., 1 min	16 – 25 Hz
Unprotected Mode	
Max Operating Freq., Continuous ⁶	25 Hz <i>Overheat protection disabled</i>
Mechanical Specifications	
Aperture Diameter	0.508" (12.9 mm)
Boxed Weight	3 lbs (1.4 kgs)
Number of Blades	5
Blade Finish	SHB05: Polished Stainless Steel SHB05T: PTFE Coated
Electrical Specifications (Power Supply)	
AC Line Voltage, Frequency	100 – 240, 47 – 63 Hz
AC Current	0.4 A
DC Voltage	5.0 VDC @ 2.4A

³ Measured using the minimum drive pulse (MDP) of 29 ms measured at 50% open.

⁴ Referenced to the external input drive pulse over a range of 4 to 15 Hz.

⁵ Measured 50 times repeatedly over a range of 4 to 15 Hz.

⁶ Shutter can get very hot if used outside of heat-sinking mount, allow 5 minutes to cool before handling.

Chapter 6 Interface Connector

The interface connector on the SHB05(T) controller is a 4-pin mini-DIN shielded female connector that accepts the 4 pin mini-DIN male connector.

The pin descriptions are as follows:

Pin	Description
1	Shutter Detect
2	Modulation +
3	+5 VDC
4	Modulation -
SHIELD	GND

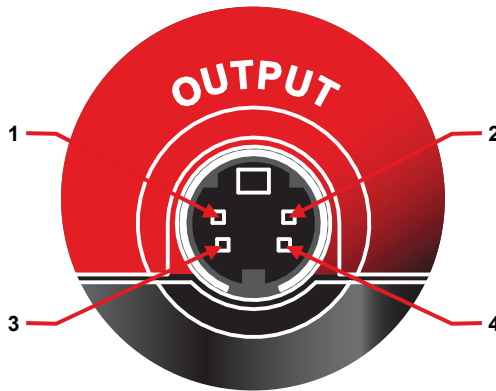

Figure 6 SHB05(T) Controller Pin-Out



Figure 7 SHB05(T) Shutter Pin-Out

Chapter 7 Cleaning and Maintenance

The SHB05(T) shutter and controller can be cleaned using a soft cloth. If needed, the cloth can be dampened with some isopropyl alcohol. Avoid using any solvents on or near the unit as well as water as this may cause the blades to rust.

The SHB05(T) incorporates five shutter blades. These blades are thin (0.003") and lightweight making them very delicate. Please do not insert any objects into the shutter where the blades may be hit. This may cause a blade to be slightly bent hampering performance.

Do not place the shutter head close to any magnetic and ferrous materials. It may affect the performance of the coils within the shutter. Maintain a distance of at least 1/8" from any ferrous materials. While both sides are susceptible, the front face is more susceptible to interference.

Chapter 8 Troubleshooting

See below for possible troubleshooting issues.

Problem	Solutions
<p>Power LED not enabled after pressing the Power ON button.</p>	<p>Check the AC cord IEC connector is properly connected to the switching power supply and that it is connected to a live AC mains outlet. Check DC plug is fully inserted into the controller's DC jack labeled 5 VDC 2.4 A.</p>
<p>Shutter does not open or close.</p>	<p>Check the SHB05(T) shutter cable 4 pin Mini-Din plug has arrow facing up and is fully inserted into the connector labeled OUTPUT.</p>
<p>Status LED turned amber.</p>	<p>In Protected Mode: Status LED should be green under normal operating conditions, and turn amber as a warning to state there are 15 seconds until shutdown (at modulation frequencies of 16 to 25 Hz). See Section 4.3.1.</p>
<p>Status LED turned red.</p>	<p>In Protected Mode: If modulation frequency is >15 Hz, a timeout period is applied to disable the shutter drive circuit after the 15 second amber LED warning.</p>
<p>Shutter operation is erratic or stuck.</p>	<p>Verify the shutter head is not located near magnetic sources or directly against ferrous materials, especially the front surface.</p>
<p>Unit powers on when DC power is applied.</p>	<p>"Default to On" mode has been set. Follow steps on Section 4.4 to disable.</p>

Chapter 9 Mechanical Drawing

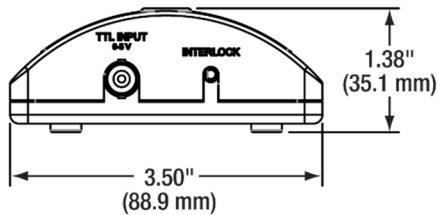
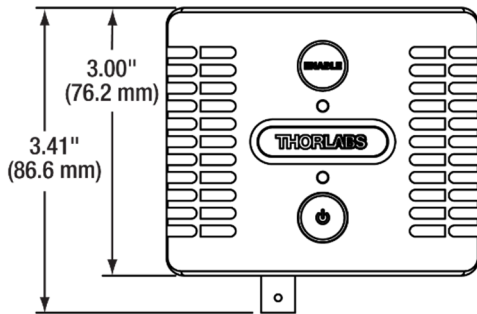
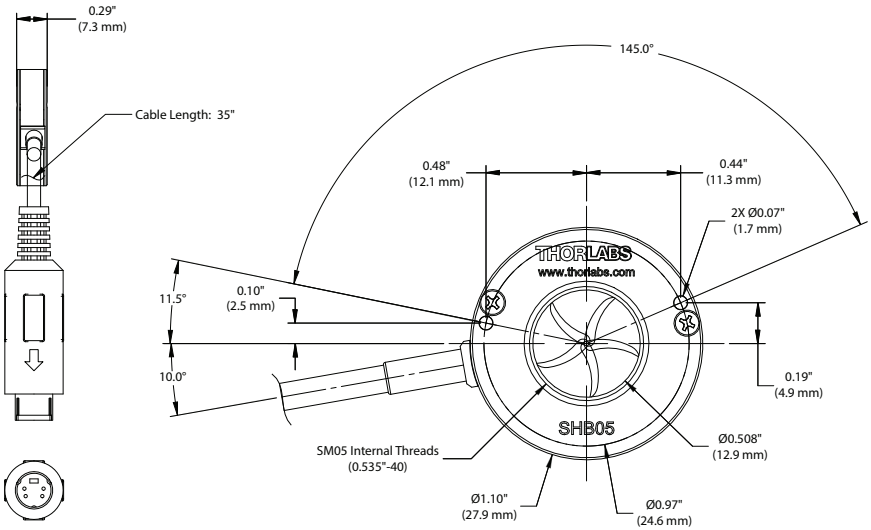

Chapter 10 Declaration of Conformity



THORLABS
www.thorlabs.com

EU Declaration of Conformity
in accordance with EN ISO 17050-1:2010

We: Thorlabs Inc.
Of: 56 Sparta Avenue, Newton, New Jersey, 07860, USA

in accordance with the following Directive(s):

2006/42/EC	Machinery Directive (MD)
2014/30/EU	Electromagnetic Compatibility (EMC) Directive
2011/65/EU	Restriction of Use of Certain Hazardous Substances (RoHS)
	Radio & Telcoms Terminal Equipment (R&TTE) Directive

hereby declare that:
Model: SHB05 and SHB05T

Equipment: Ø1/2" Stainless Steel Diaphragm Optical Beam Shutter with Controller

is in conformity with the applicable requirements of the following documents:

EN ISO 12100	Safety of Machinery. General Principles for Design. Risk Assessment and Risk Reduction	2010
EN 61326-1	Electrical Equipment for Measurement, Control and Laboratory Use - EMC Requirements	2013

and which, issued under the sole responsibility of Thorlabs, is in conformity with Directive 2011/65/EU of the European Parliament and of the Council of 8th June 2011 on the restriction of the use of certain hazardous substances in electrical and electronic equipment, for the reason stated below:

does not contain substances in excess of the maximum concentration values tolerated by weight in homogenous materials as listed in Annex II of the Directive

I hereby declare that the equipment named has been designed to comply with the relevant sections of the above referenced specifications, and complies with all applicable Essential Requirements of the Directives.

Signed:  On: 13 April 2016

Name: Ann Strachan
Position: Compliance Manager

EDC - SHB05 and SHB05T - 2016-04-13



Chapter 11 Regulatory

As required by the WEEE (Waste Electrical and Electronic Equipment Directive) of the European Community and the corresponding national laws, Thorlabs offers all end users in the EC the possibility to return “end of life” units without incurring disposal charges.

- This offer is valid for Thorlabs electrical and electronic equipment:
- Sold after August 13, 2005
- Marked correspondingly with the crossed out “wheelie bin” logo (see right)
- Sold to a company or institute within the EC
- Currently owned by a company or institute within the EC
- Still complete, not disassembled and not contaminated

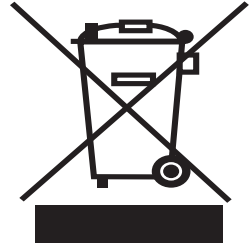

As the WEEE directive applies to self contained operational electrical and electronic products, this end of life take back service does not refer to other Thorlabs products, such as:

- Pure OEM products, that means assemblies to be built into a unit by the user (e.g. OEM laser driver cards)
- Components
- Mechanics and optics
- Left over parts of units disassembled by the user (PCB's, housings etc.).

If you wish to return a Thorlabs unit for waste recovery, please contact Thorlabs or your nearest dealer for further information.

Waste Treatment is Your Own Responsibility

If you do not return an “end of life” unit to Thorlabs, you must hand it to a company specialized in waste recovery. Do not dispose of the unit in a litter bin or at a public waste disposal site.

Ecological Background

It is well known that WEEE pollutes the environment by releasing toxic products during decomposition. The aim of the European RoHS directive is to reduce the content of toxic substances in electronic products in the future.

The intent of the WEEE directive is to enforce the recycling of WEEE. A controlled recycling of end of life products will thereby avoid negative impacts on the environment.

Chapter 12 Thorlabs Worldwide Contacts

For technical support or sales inquiries, please visit us at www.thorlabs.com/contact for our most up-to-date contact information.



USA, Canada, and South America

Thorlabs, Inc.
sales@thorlabs.com
techsupport@thorlabs.com

Europe

Thorlabs GmbH
europe@thorlabs.com

France

Thorlabs SAS
sales.fr@thorlabs.com

Japan

Thorlabs Japan, Inc.
sales@thorlabs.jp

UK and Ireland

Thorlabs Ltd.
sales.uk@thorlabs.com
techsupport.uk@thorlabs.com

Scandinavia

Thorlabs Sweden AB
scandinavia@thorlabs.com

Brazil

Thorlabs Vendas de Fotônicos Ltda.
brasil@thorlabs.com

China

Thorlabs China
chinasales@thorlabs.com



THORLABS
www.thorlabs.com
