

COUNTERBORE HOLE
FOR USE WITH
1/4-20 [M6] CAP SCREWS
3 PLACES

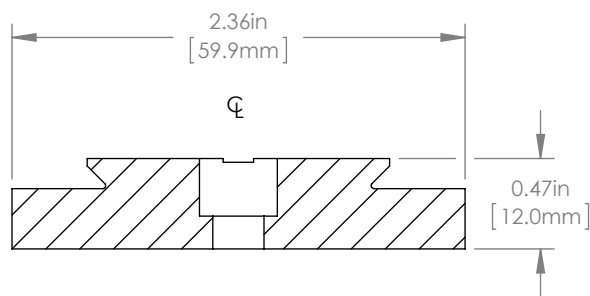

SECTION A-A

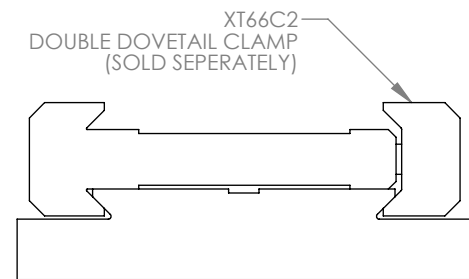
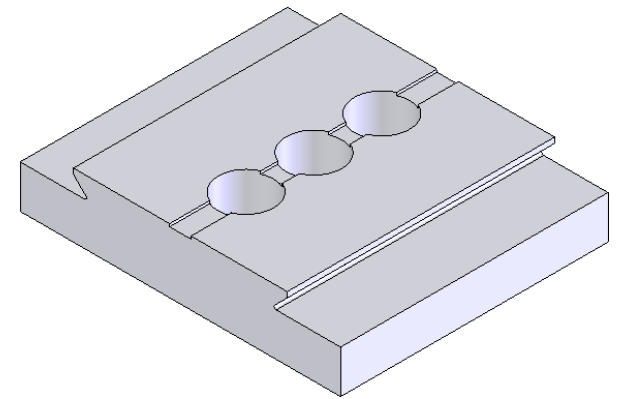

APPLICATION AID

FOR INFORMATION ONLY
NOT FOR MANUFACTURING PURPOSES

DRAWING PROJECTION			THORLABS www.thorlabs.com	
REDRAWN	NAME	DATE	XT66 Z-AXIS DOVETAIL 50.0mm	
APPROVAL	CG	27/MAY/15	MATERIAL	REV
	AK	24/AUG/15	ANODIZED ALUMINUM	A
COPYRIGHT © 2015 BY THORLABS			ITEM #	APPROX WEIGHT
VALUES IN PARENTHESIS ARE CALCULATED AND MAY CONTAIN ROUND OFF ERRORS			XT66D2-50	0.08 kg